



**PLEASE CHECK FOR CHANGE INFORMATION
AT THE REAR OF THIS MANUAL.**

THREE TERMINAL REGULATOR TEST UNIT

**POSITIVE 013-0147-00
NEGATIVE 013-0148-00**

INSTRUCTION MANUAL

Tektronix, Inc.
P.O. Box 500
Beaverton, Oregon 97077

070-1678-00
Product Group 48

Serial Number _____

First Printing APR 1974
Revised MAY 1983

Copyright © 1974 Tektronix, Inc. All rights reserved.
Contents of this publication may not be reproduced in any
form without the written permission of Tektronix, Inc.

Products of Tektronix, Inc. and its subsidiaries are covered
by U.S. and foreign patents and/or pending patents.

TEKTRONIX, TEK, SCOPE-MOBILE, and  are
registered trademarks of Tektronix, Inc. TELEQUIPMENT
is a registered trademark of Tektronix U.K. Limited.

Printed in U.S.A. Specification and price change privileges
are reserved.

INSTRUMENT SERIAL NUMBERS

Each instrument has a serial number on a panel insert, tag,
or stamped on the chassis. The first number or letter
designates the country of manufacture. The last five digits
of the serial number are assigned sequentially and are
unique to each instrument. Those manufactured in the
United States have six unique digits. The country of
manufacture is identified as follows:

B000000	Tektronix, Inc., Beaverton, Oregon, USA
100000	Tektronix Guernsey, Ltd., Channel Islands
200000	Tektronix United Kingdom, Ltd., London
300000	Sony/Tektronix, Japan
700000	Tektronix Holland, NV, Heerenveen, The Netherlands

TABLE OF CONTENTS

	Page
Section 1 SPECIFICATION	
Description	1-1
Electrical Characteristics	1-1
Common-Terminal Supply	1-1
Output Buffer	1-1
Display	1-1
Vertical Deflection Factor	1-2
Output Voltage Comparison	1-2
Environmental Characteristics	1-2
Temperature	1-2
Altitude	1-2
Transportation	1-2
 Section 2 OPERATING INFORMATION	
Function of Controls and Connectors ..	2-1
Supply Voltage and Horiz Volts/Div Mult	2-1
0-30 V	2-1
0-60 V	2-1
Output Voltage Comparison Dial	2-1
Ten Turn Control	2-1
Output Voltage Comparison Range	
Switch	2-1
0-10 V Manual	2-1
0-100 V Manual	2-1
0-100 V \pm 6 V Auto	2-1
Output Voltage Comparison Cal	2-1
Screwdriver Adjustment	2-1
Some Operating Aids	2-1
Procedure for Testing Three-Terminal	
Regulators	2-4
1. Setting the DUT Load Current	2-4
2. Setting the Input Voltage to the	
Device Under Test (DUT)	2-5
3. Setting the Comparison Voltage ..	2-5
4. Initial Setup	2-5
5. Making the Tests	2-9
Line Regulation	2-9
Load Regulation	2-9
Common-Terminal Current	2-10
Examples of Typical Test Setups	2-11
1. Load Regulation	2-11
2. Line Regulation	2-12
3. Quiescent or Common Current ..	2-14

	Page
Section 2 OPERATING INFORMATION (Cont'd)	
Applications	2-16
Ripple Rejection Test	2-16
Dropout Voltage Test	2-17

WARNING

THE FOLLOWING SERVICING INSTRUCTIONS ARE FOR USE BY QUALIFIED PERSONNEL ONLY. TO AVOID PERSONAL INJURY, DO NOT PERFORM ANY SERVICING OTHER THAN THAT CONTAINED IN OPERATING INSTRUCTIONS UNLESS YOU ARE QUALIFIED TO DO SO.

Section 3 CIRCUIT DESCRIPTION	
General	3-1
Regulator Input Supply	3-1
Output Voltage Comparison	3-3
Output Buffer	3-3
Common-Terminal Current	3-3
Internal Voltage Supplies	3-3
Display Positioning	3-4

Section 4 MAINTENANCE	
General	4-1
Top-Panel Removal	4-1
Heat-Sink (Input Regulator Supply Card)	
Removal	4-1
Output-Voltage Comparison-Dial	
Mechanical Position	4-1
Troubleshooting Aids	4-1

Section 5 PERFORMANCE CHECK PROCEDURE	
Introduction	5-1
Test Equipment Required	5-1
Performance Check	5-1

Section 6 ELECTRICAL PARTS LIST

Section 7 DIAGRAMS AND CIRCUIT BOARD ILLUSTRATIONS

Section 8 MECHANICAL PARTS LIST AND ILLUSTRATIONS

CHANGE INFORMATION

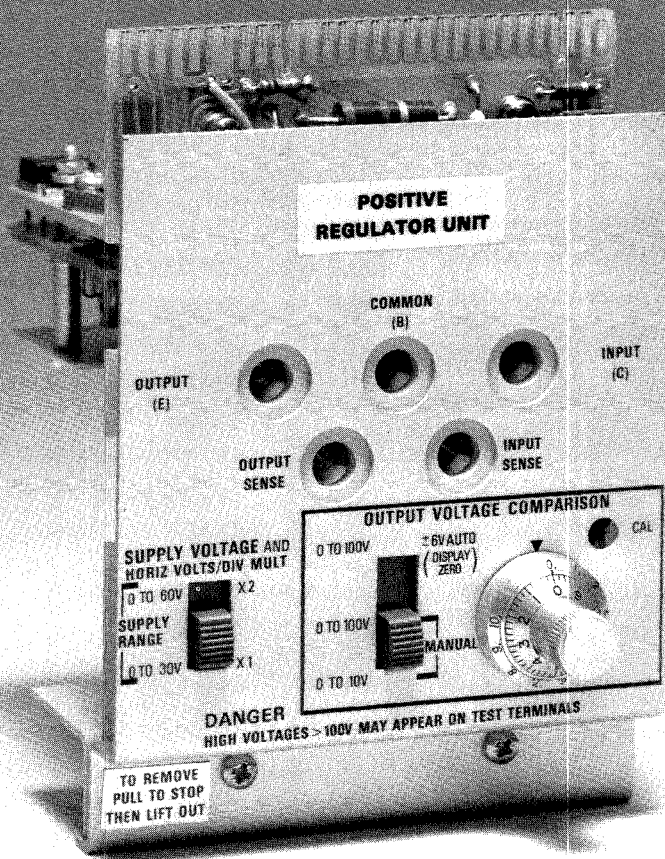

Fig. 1-1. Three-Terminal Regulator Test Unit.

SPECIFICATION

DESCRIPTION

The Three-Terminal Regulator Test Unit is a plug-in accessory for the 178 Linear IC Test Fixture.

The Regulator Test Unit contains a regulated Input supply, common-terminal supply, output buffer, and an output voltage comparator.

The Input supply is a power feedback amplifier that regulates the 577 Collector Supply to provide DUT (Device Under Test) input voltages up to 60 V. The Input Supply voltage is adjusted from the 178 +SUPPLY dial for either X1 or X2 dial indication. The Input supply voltages can be swept in the LINE REGULATION tests at a rate and amplitude determined by the 178 Sweep Frequency and Amplitude controls.

The common-terminal supply produces an artificial ground through which DUT common terminal current is measured.

The Output Voltage Comparator has three modes: 1(0-10 V, 2(0-100 V, and 3(0-100 V, ± 6 V, AUTO. The Output Voltage Comparator provides a dc offset for the crt display. In the first two modes, the offset voltage is calibrated.

In the 0-100 V, ± 6 V AUTO mode, the DUT dc output display voltage is automatically offset (within a ± 6 V range) when the 178 Display Zero button is pushed and the dial is within 6 volts of the actual output voltage.

The 577 Step Generator provides a current load for the DUT. A buffer in the Test Unit provides voltage compliance through the output range in which the DUT can operate.

ELECTRICAL CHARACTERISTICS

INPUT SUPPLY

Voltage

0-30 V: +SUPPLY dial setting, $\pm 2\%$, ± 200 mV.

0-60 V: Twice +SUPPLY dial setting, $\pm 2.5\%$, ± 300 mV.

Output Regulation: 250 mV, with load currents from 5 mA to 2 A, after recovery time of 50 μ s.

Sweep Amplitude (in LINE REGULATION function): 25 V, p-p at sweep frequencies of 20 Hz or less. At least

$$\frac{500 \text{ V, p-p}}{\text{Freq (Hz)}} \text{ Above 20 Hz}$$

Current

Pulsed Load Current, 300 μ s: At least 2 A.

Short-Duration DC Current (one minute, 20% duty cycle):

	+SUPPLY VOLTS Current	
MAX PEAK VOLTS, 25	0-8	700 mA
MAX PEAK VOLTS, 100	10-20	350 mA
	20-40	300 mA
	40-60	120 mA
Continuous DC Current:		
MAX PEAK VOLTS, 25		200 mA
MAX PEAK VOLTS, 200		50 mA

COMMON-TERMINAL SUPPLY

Voltage: 0 V, ± 10 mV.

Current: At least 15 mA.¹

OUTPUT BUFFER

Maximum Voltage: 60 V.

Current load: 2 A, Maximum

Accuracy: 3%, + 0 to 1.25 mA.

DISPLAY

Horizontal Deflection Factor

In LOAD REGULATION and I COMMON

Unmagnified: $\pm 4\%$.

Magnified: $\pm 5\%$.

¹The -SUPPLY OVERLOAD lamp (+SUPPLY OVERLOAD for negative regulators) may turn on as the current nears the 15 mA limit. The display accuracy is unaffected when lamp lights as long as current is below the 15 mA limit.

Specification—013-0147-00/013-0148-00

In LINE REGULATION, SUPPLY VOLTAGE AND
HORIZ VOLTS/DIV MULT

X1, horizontal unmagnified: $\pm 3\%$, ± 200 mV.

Horizontal magnified: $\pm 4\%$, ± 200 mV.

X2, horizontal unmagnified: Twice HORIZ
VOLTS/DIV control setting, $\pm 3\%$, ± 300 mV.

Horizontal magnified: $\pm 4\%$, ± 300 mV.

In COLLECTOR SUPPLY

Unmagnified: $\pm 3\%$.

Magnified: $\pm 4\%$.

VERTICAL DEFLECTION FACTOR

Accuracy

In LOAD REGULATION and LINE REGULATION

1 mV/DIV to 50 mV/DIV, unmagnified: $\pm 3.5\%$.

.1 mV/DIV to 5 mV/DIV, magnified: $\pm 4.5\%$.

In I COMMON

10 μ A/DIV to 5 mA/DIV: $\pm 3\%$.

In COLLECTOR SUPPLY

1 μ A/DIV to 50 mA/DIV: $\pm 3\%$.

OUTPUT VOLTAGE COMPARISON

Accuracy of Vertical DISPLAY ZERO reference point
on crt.

In LOAD REGULATION and LINE REGULATION

0-10 V, MANUAL: $\pm 1\%$, ± 20 mV.

0-100 V, MANUAL: $\pm 1\%$, ± 150 mV.

0-100 V, ± 6 V AUTO: The automatic nulling
range is at least 6 V from OUTPUT VOLTAGE
COMPARISON dial setting. No dc reference on
display.

ENVIRONMENTAL CHARACTERISTICS

TEMPERATURE

Specified Operating: $+10^{\circ}\text{C}$ ($+50^{\circ}\text{F}$) to $+40^{\circ}\text{C}$
($+104^{\circ}\text{F}$).

Useful Operating: 0°C ($+32^{\circ}\text{F}$) to $+50^{\circ}\text{C}$ ($+120^{\circ}\text{F}$).

Non-Operating: -40°C (-40°F) to $+65^{\circ}\text{C}$ ($+149^{\circ}\text{F}$).

ALTITUDE

Operating: To 10,000 feet.

TRANSPORTATION

12-inch package drop: Qualified under the National
Safe Transit Committee procedure 1A.

OPERATING INFORMATION

FUNCTION OF CONTROLS AND CONNECTORS

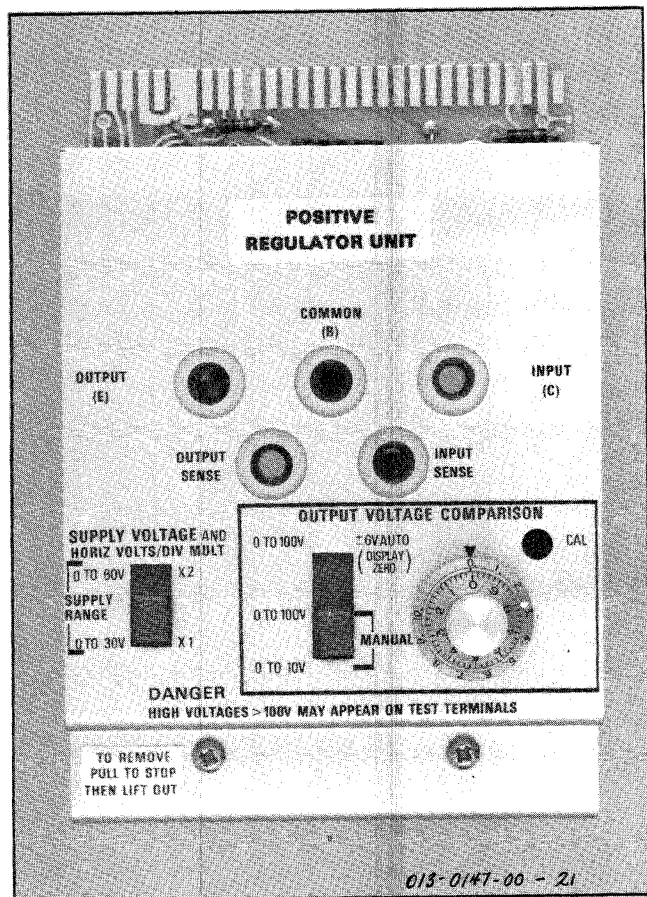

Fig. 2-1. Location of controls and connectors.

SUPPLY VOLTAGE AND HORIZ VOLTS/DIV MULT

SUPPLY RANGE

0-30 V Selects a zero to thirty-volt supply range. Level is set within the range by the +SUPPLY dial on the 178. When testing negative regulators, the -SUPPLY must be in TRACK +SUPPLY.

0-60 V Selects a zero to sixty-volt supply range. Level is set within the range by the +SUPPLY dial on the 178. The +SUPPLY dial must be multiplied by two in this range. The HORIZ VOLTS/DIV switch setting must also be multiplied by two.

OUTPUT VOLTAGE COMPARISON Dial

Ten-Turn Control Sets the level of output comparison voltage to provide a calibrated display offset. The display position indicates the difference in the DUT output voltage and the comparison voltage. The comparison dial indicates either 0 to 10 volts or 0 to 100 volts, depending upon the range switch position.

OUTPUT VOLTAGE COMPARISON Range Switch

0-10 V MANUAL Sets the output voltage comparison range from 0 to 10 volts. The level is set within the range by the OUTPUT VOLTAGE COMPARISON dial.

0-100 V MANUAL Sets the output voltage comparison range from 0 to 60 volts. The level is set within the range by the OUTPUT VOLTAGE COMPARISON dial (dial indicates from 0 to 100 volts).

0-100 V ±6 V AUTO Sets the output voltage comparison range from 0 to 60 volts. If the comparison dial is set within ±6 V of the DUT output voltage, the circuit provides automatic comparison voltage when the DISPLAY ZERO button is pressed. The display is not dc calibrated in AUTO mode. The dial indicates from 0 to 100 volts.

OUTPUT VOLTAGE COMPARISON CAL

Screwdriver Adjustment Sets the comparison voltage if precise comparison dial voltage measurement accuracy is required. See the Check Procedure, Section 5.

SOME OPERATING AIDS

Fig. 2-2 is a simplified block diagram of the Three-Terminal Regulator Test Unit. The diagram shows test unit connection to the 178 and 577 for testing positive regulators.

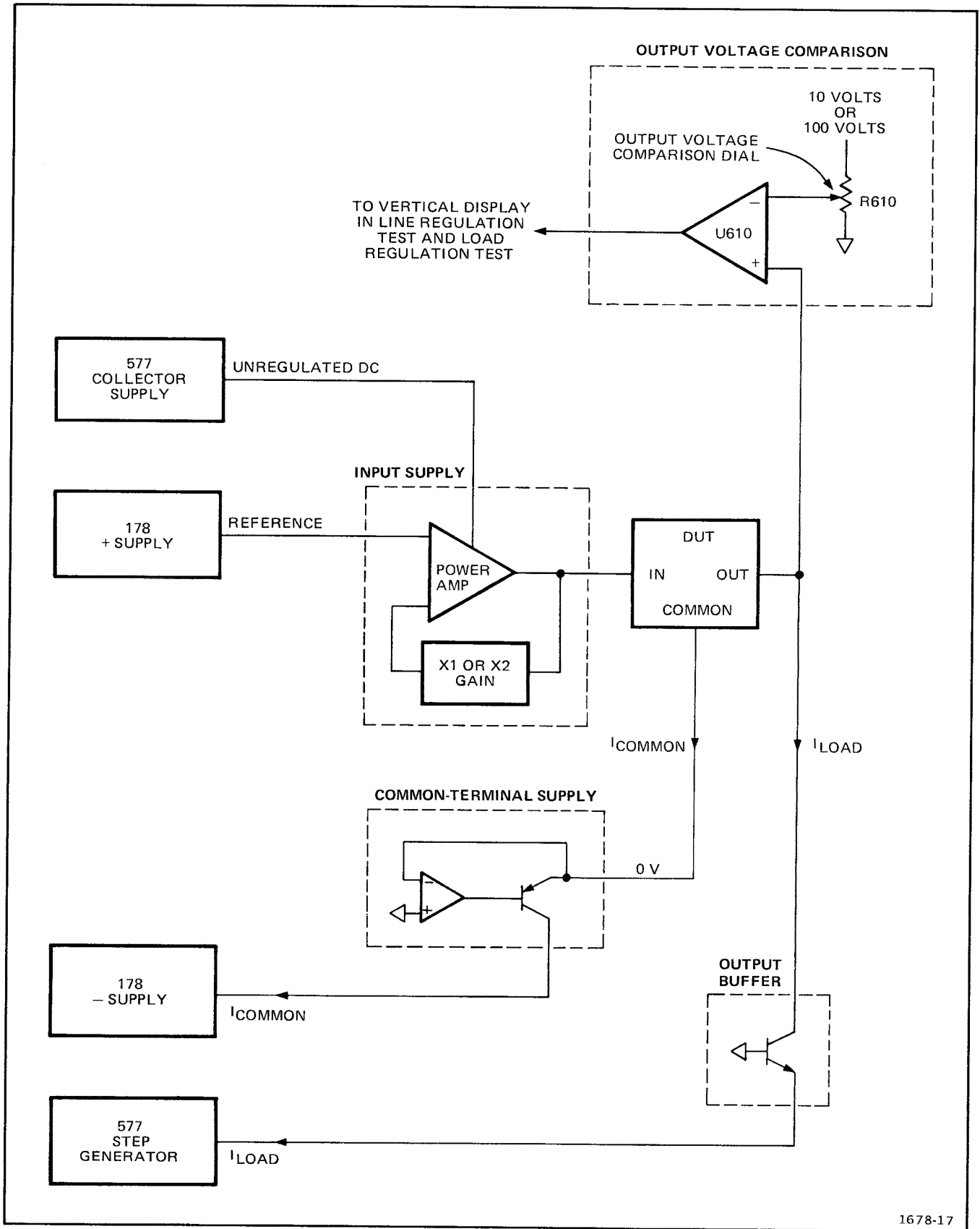

Fig. 2-2. Simplified block diagram of the Three-Terminal Regulator Test Unit.

Table 2-1 lists the FUNCTION switch position, test function, and the parameters displayed on the graticule for each test. Use the Positive Regulator Function

nomenclature panel with the Positive Regulator Test Unit and the Negative Regulator Function nomenclature panel for Negative Regulator Test Unit. See Fig. 2-3.

TABLE 2-1

Test Position		Function	Vertical Display	Horizontal Display
-Reg	+Reg			
7	7	LINE REGULATION	DUT Output Voltage	Swept DUT Input Voltage
5	5	LOAD REGULATION	DUT Output Voltage	Step Generator Load Current
9	10	I COMMON	Common-Terminal Current	Step Generator Load Current
11	11	COLLECTOR SUPPLY	Collector-Supply Current	Collector Supply Voltage

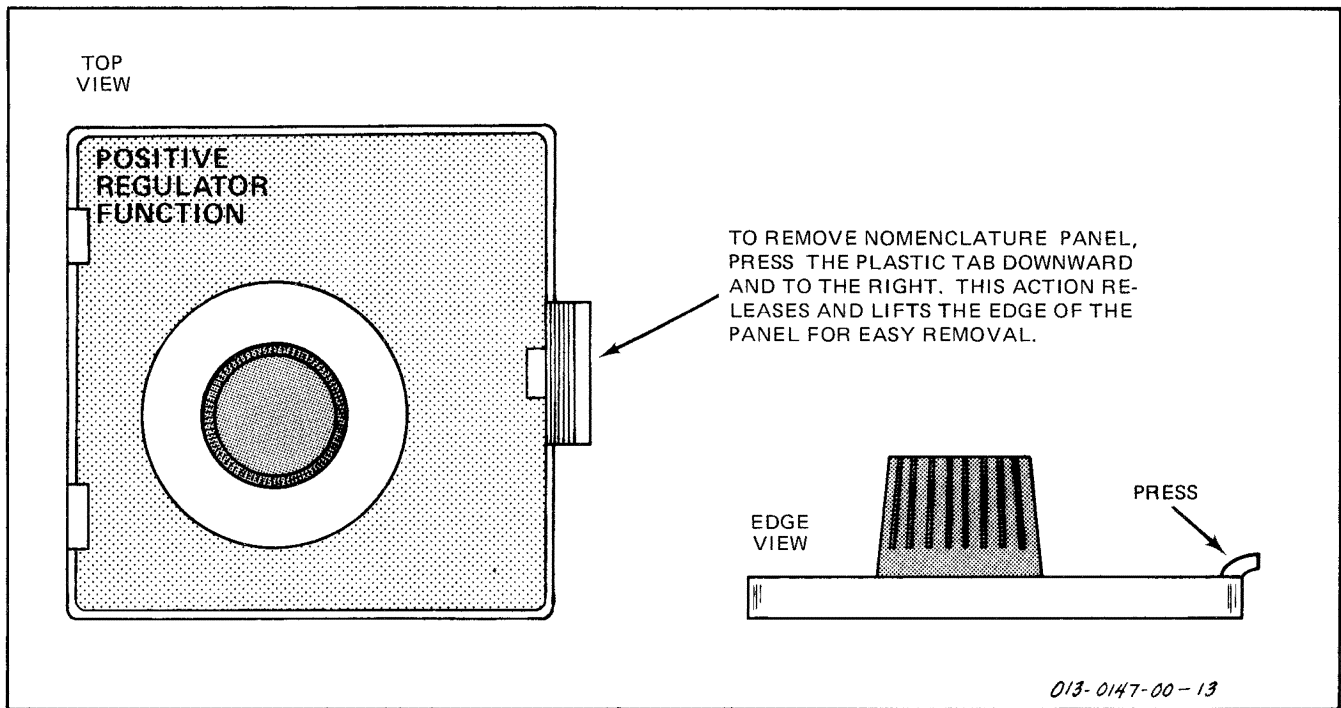

Fig. 2-3. Removing the Function switch nomenclature panel.

Operating Information—013-0147-00/013-0148-00

OVERLOAD lamps can indicate misadjusted controls or incorrect switch settings. Table 2-2 lists the conditions that light the OVERLOAD lamps, and which lamps are lighted for each condition.

TABLE 2-2

For Positive Regulators

(Use Positive Regulator Test Unit)

Use Positive Regulator Nomenclature Panel

See Fig. 2-3

Condition	OVERLOAD Lamp for	
	+SUPPLY	-SUPPLY
Test Unit not plugged in completely	ON	ON
VARIABLE COLLECTOR % set too low (Input supply out of regulation. Increase VARIABLE COLLECTOR % or reduce load. Recheck, MAX PEAK POWER at 100 W	ON	
VARIABLE COLLECTOR % set too high ¹	ON	
Thermal cutout opens on high chassis temperature (reset time, approx 3 minutes) ²	ON	
Common current too high ³		ON
COLLECTOR SUPPLY POLARITY not in +DC	ON	
COLLECTOR SUPPLY CIRCUIT BREAKER open	ON	

¹When switching MAX PEAK VOLTS to 100, Interlock Defeat button pushed, and VARIABLE COLLECTOR % too high, OVERLOAD lamp lights. Decrease VARIABLE COLLECTOR % while pushing and releasing Interlock Defeat Button until lamp is on with button in.

²HOT !!! The thermal cutout opens at approximately 100°C. Avoid touching the chassis on which the cutout is mounted.

³The maximum current is 15 mA, however the lamp may come on before reaching the maximum. Disregard the lamp as long as the common-terminal current is below 15 mA.

TABLE 2-2 (cont)

For Negative Regulators

(Use Negative Regulator Test Unit)

Use Negative Regulator Function Nomenclature Panel

See Fig. 2-3

Condition	OVERLOAD Lamp for	
	+SUPPLY	-SUPPLY
Test Unit not plugged in completely	ON	ON
VARIABLE COLLECTOR % set too low (Input supply out of regulation. Increase VARIABLE COLLECTOR % or reduce load. Recheck MAX PEAK POWER at 100 W		ON
VARIABLE COLLECTOR % set too high ¹		ON
Thermal cutout opens on high chassis temperature (reset time, approx 3 minutes) ²		ON
Common current too high ³	ON	
COLLECTOR SUPPLY POLARITY not in -DC		ON
COLLECTOR SUPPLY CIRCUIT BREAKER open		ON

PROCEDURE FOR TESTING THREE-TERMINAL REGULATORS

1. SETTING THE DUT LOAD CURRENT

The Step Generator in the 577 is used as a current load for the DUT output. The load is selected by the STEP/OFFSET AMPL (in the current positions only). Set the STEP GENERATOR POLARITY NORM button to the out position. Current load may be dc or discrete steps, or both, according to the following:

Press OFFSET MULT ZERO button in for no dc load current.

Release OFFSET MULT ZERO and press AID button for dc load current, adjusted by OFFSET MULT dial.

Press STEP FAMILY REP to generate discrete load current steps.

Press STEP FAMILY SINGLE to turn off discrete load current steps.

The discrete steps of load current can be provided in 300 μ s pulses by pressing the PULSED 300 μ s button. The duty cycle will be approximately 4% when the NORM rate button is pressed. The duty cycle will be approximately 2% when the SLOW rate button is pressed. DC load current is unaffected by the 300 μ s button.

The discrete-step current amplitude can be decreased by 10 by releasing the STEP X.1 multiplier button. The number of steps increases when STEP X.1 is released so that the highest discrete current step remains at about the same level. DC load current is unaffected by the STEP X.1 button.

See the 577-D1 or D2 Operators Manual for more details on Step Generator Operation.

2. SETTING THE INPUT VOLTAGE TO THE DEVICE UNDER TEST (DUT).

The voltage supply for the DUT input is derived from the 577 Collector Supply and regulated in the Regulator Test Unit. Set the COLLECTOR SUPPLY POLARITY to +DC for positive regulators and the -DC for negative regulators. Set MAX PEAK POWER to 100 W. See operation of Collector Supply in 577-D1 or D2 manual if more detail is desired. Set the required DUT input voltage using the calibrated +SUPPLY dial on the 178. The -SUPPLY must be in TRACK +SUPPLY position. The Input Supply range is either 0-30 V or 0-60 V, depending upon the SUPPLY VOLTAGE switch on the Regulator Test Unit. When in the 0-60 V range, double both the +SUPPLY dial and the HORIZ VOLTS/DIV indications.

Next, set the MAX PEAK VOLTS of the Collector Supply to the 25 V or 100 V position.⁴ Use 100 V setting if the required DUT input voltage is greater than 10 to 12 volts. Adjust the Collector Supply voltage, using the VARIABLE COLLECTOR % control, to extinguish the OVERLOAD lamp.

If the Collector Supply voltage is not in the correct operating range, the OVERLOAD lamp lights, indicating that the Collector Supply voltage is either too high or too low.

⁴See Fig. 2-4 for maximum voltage and current conditions.

The yellow COLLECTOR SUPPLY DISABLED lamp on the 577 indicates that the Collector Supply is off, and either the MAX PEAK VOLTS switch is set at 100 V or the DUT SUPPLIES switch (on the 178) is set to OFF. When the MAX PEAK VOLTS switch is set to 100 V, press the Interlock Defeat button (red button on the 178 front panel) to turn on the Collector Supply. The Interlock Defeat button must be held in while making the test. The red lamp on the 178 indicates that dangerous voltages may appear at the test terminals.

3. SETTING THE COMPARISON VOLTAGE

The Output Voltage Comparison provides a calibrated display offset voltage for accurate dc measurements and for examining small voltage changes in the dc voltage level. Set the OUTPUT VOLTAGE COMPARISON dial to the nominal DUT output voltage. The difference in the DUT output voltage and the Comparison Voltage Reference is displayed on screen at a sensitivity selected by the VERT UNITS/DIV switch.

Pushing the DISPLAY ZERO button provides the vertical reference when the graticule is calibrated to the OUTPUT VOLTAGE COMPARISON dial voltage. The null point on the graticule has a dc level equal to the comparison voltage. This comparison voltage has two manual ranges, 0-10 V and 0-100 V, and an automatic range in which the DUT dc output voltage is automatically nulled (if the OUTPUT VOLTAGE COMPARISON dial setting is within ± 6 volts of the DUT output voltage) by pushing the DISPLAY ZERO button. In the 0-100 V, ± 6 V AUTO mode, there is no calibrated dc reference on the graticule. The DUT output voltage is found by connecting a DVM between the EXT INPUT SIGNAL and GND on the 178 front panel (the EXT INPUT SIGNAL circuit has a 10 k Ω output impedance with the Regulator Test Unit installed.).

4. INITIAL SETUP

Set the DUT SUPPLIES switch to OFF.

Install a compensating capacitor, if necessary, on the Regulator Test Unit circuit board, as shown in Fig. 2-5. See the device specification for capacitor value. Plug the Regulator Test Unit into the 178. See Fig. 2-6.

Install the regulator into the appropriate adapter (Fig. 2-7. shows the adapter used with each of the regulator packages, and terminal configurations). Plug the adapter into the Regulator Test Unit.

Set the desired load current in accordance with the DUT test specifications. See Table 2-3 for definitions of terms used in the manufacturers specifications.

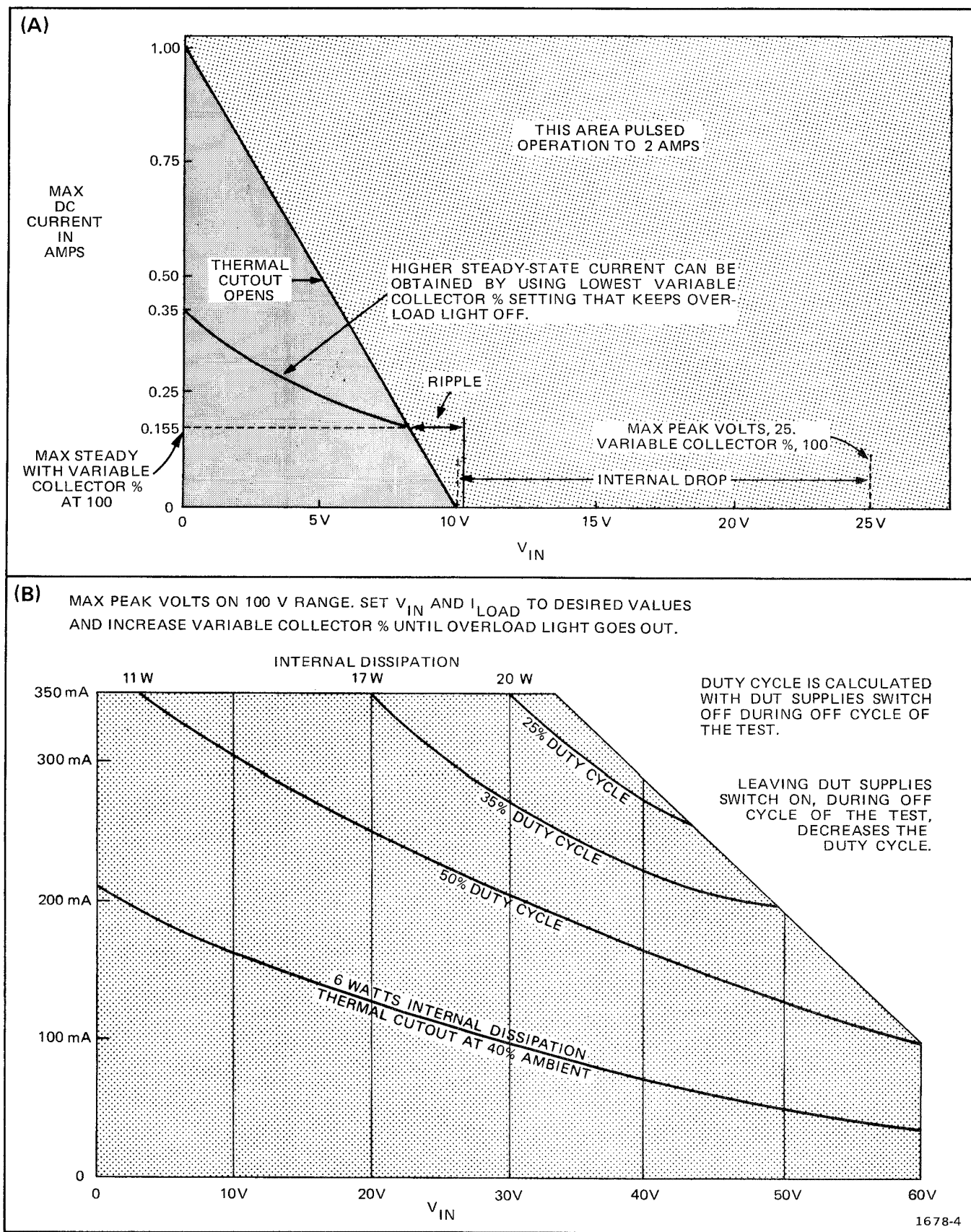

Fig. 2-4. Regulator Test Unit current and voltage limits.

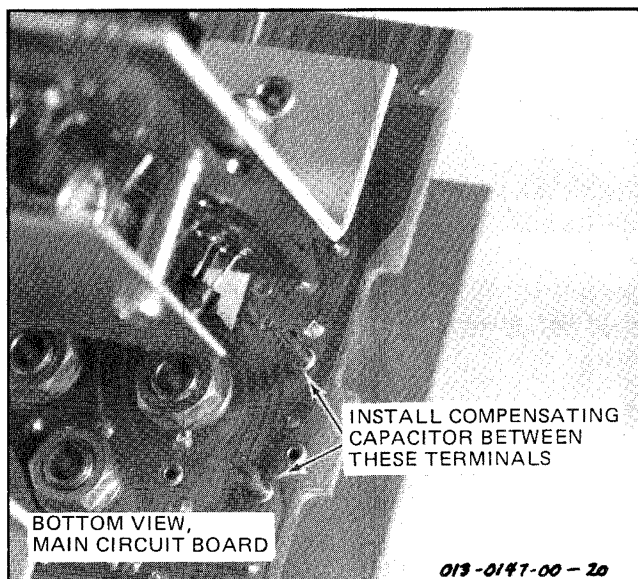

Fig. 2-5. Location of compensating capacitor terminals.

Power dissipation in the DUT must be taken into account, as well as current and voltage ratings of the Regulator Test Unit.

High current and power levels should use the pulsed mode of operation to limit average power. In pulsed mode, the high current pulse exists for only 300 μ s, with a duty cycle of 4% in NORM and 2% in SLOW step rates. Between pulses, the current load is zero, or some small dc current selected by the OFFSET MULT dial.

Set the input voltage according to the DUT specifications and part two of this section. First, set the required voltage, using +SUPPLY dial and SUPPLY VOLTAGE Range switch.

Set VARIABLE COLLECTOR % to 0. Switch DUT SUPPLIES to ON, press and hold the Interlock Defeat button, if necessary, and increase VARIABLE COLLECTOR % until OVERLOAD LAMP goes out.

Set the OUTPUT VOLTAGE COMPARISON Range switch and dial to the DUT nominal output voltage (see part three for details).

Press and hold DISPLAY ZERO button and position the spot to left-center graticule (right-center graticule for Negative Regulator Test Units), using vertical and horizontal POSITION controls.

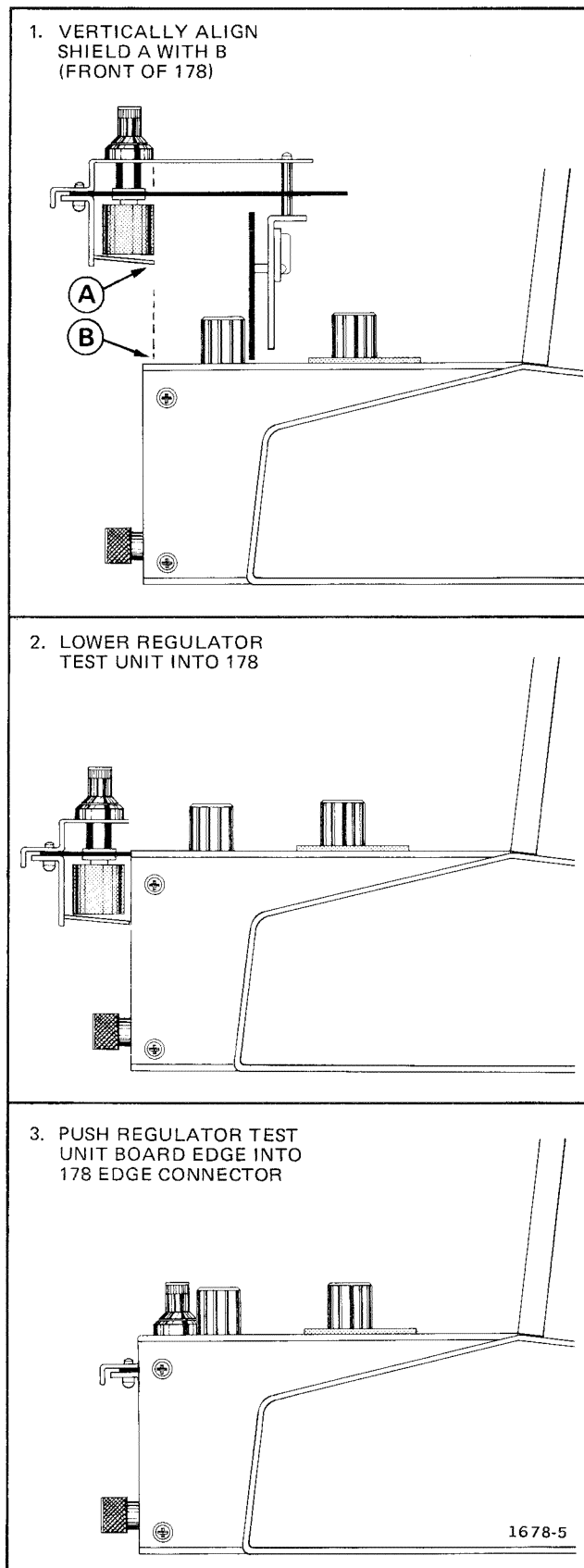

Fig. 2-6. Placing the Regulator Test Unit in the 178.

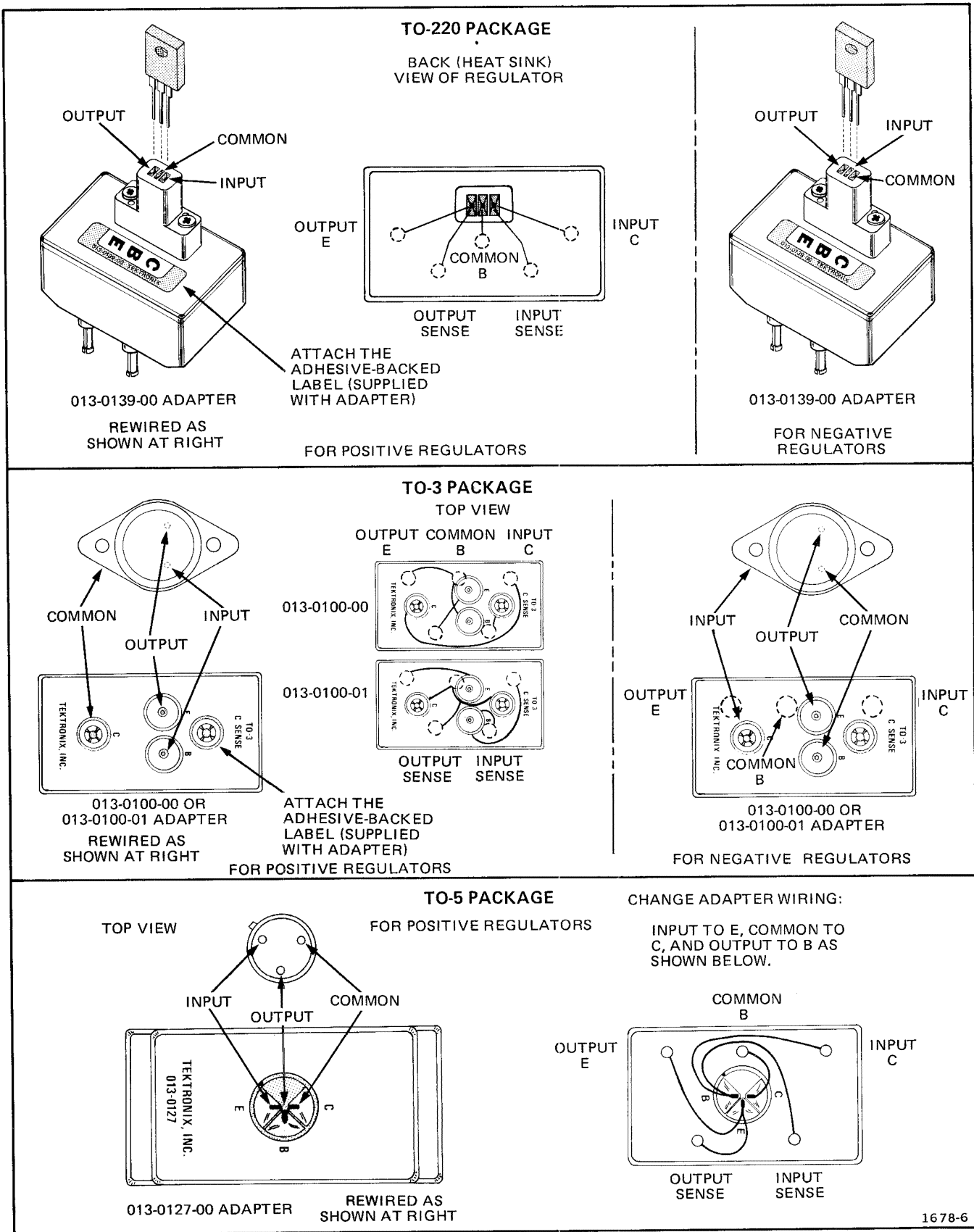

Fig. 2-7. Adapter and regulator terminal configurations.

TABLE 2-3

Definitions of Terms Used in Regulator Specifications

Line Regulation—The change in output voltage for a change in input voltage. The measurement is made under conditions of low dissipation or by using pulse techniques such that the average chip temperature is not significantly affected.

Load Regulation—The change in output voltage for a change in load current at constant chip temperature.

Maximum Power Dissipation—The maximum total device dissipation for which the regulator will operate within specifications.

Quiescent Current (Common-Terminal Current)—That part of the input current that is not delivered to the load.

Output Noise Voltage—The rms ac voltage at the output with constant load and no input ripple, measured over a specified frequency range.

Long Term Stability—Output voltage stability under accelerated life test conditions, with the maximum rated voltage listed in the device's electrical characteristics and maximum power dissipation.

V_{OR} —Output voltage range.

I_O or I_{OUT} —Output current.

$(V_{IN} - V_{OUT})$ —Input-output voltage differential.

V_{IN} —Input Voltage.

V_{REF} —Reference Voltage.

I_{IB} —Input Bias (standby) Current.

REG_{IN} —Line Regulation Voltage.

REG_L —Load Regulation Voltage.

TC_{VO} —Temperature Coefficient of Output Voltage.

P —Power Dissipation.

T_J —Junction Temperature.

5. MAKING THE TESTS

LINE REGULATION. In the Line Regulation tests, the vertical display is output voltage and the horizontal display is input voltage. Set load current, input voltage and comparison voltage according to the initial setup, part four of this section.

Set FUNCTION switch to LINE REGULATION.

Set VERT UNITS/DIV to 50 mV. The sensitivity should be increased to an appropriate value when the measurement is made.

Set HORIZ VOLTS/DIV to a value appropriate to display the DUT input voltage.

Press and release BEAM FINDER to locate the spot, if off screen. Position the spot vertically to graticule center, using the OUTPUT VOLTAGE COMPARISON dial (if the spot is off screen above the top graticule line, turn the OUTPUT VOLTAGE COMPARISON dial clockwise. Turn counterclockwise if off screen below bottom graticule line. Turn dial opposite these stated directions for a Negative Regulator Test Unit).

Set SWEEP FREQUENCY to about .1 Hz and turn the SWEEP AMPLITUDE control clockwise to produce a curve on the crt. See Fig. 2-10 in example 2. Example 2 gives typical values for a 5-volt regulator. Adjust VERT UNITS/DIV to obtain a sloping line.

Line regulation is equal to the change in output voltage (vertical) divided by the change in input voltage (horizontal).

LOAD REGULATION. In the Load Regulation test, the vertical display is output voltage and the horizontal display is load current. The load current is displayed from right to left (left to right for negative regulators). The display is a set of markers indicating the Step Generator output at one step/division (normal amplitude step).

Set load current, input voltage, and comparison voltage according to initial setup (part four) unless proceeding from the previous test.

Set FUNCTION switch to LOAD REGULATION.

Set VERT UNITS/DIV switch to 50 mV or leave in position used in Line Regulation.

Operating Information—013-0147-00/013-0148-00

Set HORIZ VOLTS/DIV to STEP GEN.

Press and hold DISPLAY ZERO button while positioning the spot to right-center graticule (left-center graticule for negative regulator test units), using vertical and horizontal POSITION controls.

Press and release BEAM FINDER button to locate the spot, if off screen. Position the spot vertically to graticule center using OUTPUT VOLTAGE COMPARISON dial (clockwise if above top of graticule and counterclockwise if below bottom of graticule). Example 1 gives typical values for testing a 5-volt positive regulator. Adjust STEP/OFFSET AMPL, NUMBER OF STEPS, and STEP X.1, when necessary to provide adequate load current display.

Adjust VERT UNITS/DIV to show changes in output voltage.

Load regulation is equal to the change in output voltage (vertical) divided by the change in load current (horizontal).

COMMON-TERMINAL (QUIESCENT) CURRENT. In I COMMON test, the vertical display is common-terminal current and the horizontal is load current.

Set load current and input voltage according to initial setup (part four) or proceed from LOAD REGULATION test.

Set FUNCTION switch to I COMMON.

Set VERT UNITS/DIV to 5 mA.

Set HORIZ VOLTS/DIV to STEP GEN.

Press and hold the DISPLAY ZERO button and position the spot to right-center graticule (left-center graticule for negative regulators), using the 577 POSITION controls.

Read the common-terminal current on the vertical axis. The VERT UNITS/DIV setting in this function indicates current. Increase VERT UNITS/DIV to appropriate range, 5 mA to 10 μ A, to provide adequate resolution. See Fig. 2-10 in example 3. Example 3 give typical values for testing a 5-volt positive regulator.

EXAMPLES OF TYPICAL TEST SETUPS

1. LOAD REGULATION

For a positive 5-volt regulator, such as the 7805C, having the following characteristics:

ELECTRICAL CHARACTERISTICS (V IN =10 V and I OUT =500 mA)

Parameter	Conditions	Min	Typ	Max	Units	
Output Voltage	T J =25°C	4.8	5.0	5.2	V	
Load Regulation	T J =25°C	5 mA ≤ I OUT ≤ 1.5 A		15	100	mV
		250 mA ≤ I OUT ≤ 750 mA		5	50	mV

a. Set the controls as follows:

577

MAX PEAK VOLTS 25
 MAX PEAK POWER-WATTS 100
 VARIABLE COLLECTOR % 100
 COLLECTOR SUPPLY POLARITY +DC

All Dark Gray Buttons and Knobs In Except:

STEP/OFFSET POLARITY NORM out (invert)
 STEP FAMILY SINGLE
 STEP X.1 out
 PULSED 300 μs out
 STEP/OFFSET AMPL 20 mA
 NUMBER OF STEPS 1 (ccw)
 HORIZ VOLTS/DIV STEP GEN

178

DUT SUPPLIES OFF
 +SUPPLY 10
 -SUPPLY TRACK +SUPPLY
 FUNCTION LOAD REGULATION
 VERT UNITS/DIV 50 mV

Regulator Test Unit

SUPPLY VOLTAGE Range 0-30
 OUTPUT VOLTAGE COMPARISON Range 0-10
 OUTPUT VOLTAGE COMPARISON Dial ≈5 V

b. Place a compensating capacitor (value shown in regulator specification) on the Regulator Test Unit circuit board as shown in Fig. 2-5.

c. Plug the regulator into the adapter socket.

d. Switch DUT SUPPLIES switch ON.

e. Press DISPLAY ZERO button and position spot to right-center graticule, using vertical and horizontal POSITION controls. Release DISPLAY ZERO button.

f. Press and hold BEAM FINDER button (on Display Unit) and adjust OUTPUT VOLTAGE COMPARISON dial until spot is at right-center graticule when BEAM FINDER is released.

NOTE

The OUTPUT VOLTAGE COMPARISON dial setting is the regulator output voltage with no load. See "no load output voltage specification".

g. Push PULSED 300 μs and STEP FAMILY REP buttons in. Turn NUMBER OF STEPS fully clockwise (≈95 steps).

h. Observe a display as shown in Fig. 2-8A. Reset VERT UNITS/DIV until the display nearly goes off screen vertically at about 7.5 divisions horizontally (from the display start). See Fig. 2-8B. 7.5 horizontal divisions equal 1.5 A. the upper specified limit.

i. Store the display and turn INTENSITY control counterclockwise.

j. Reset STEP/OFFSET AMPL to .5 mA. Increase INTENSITY to produce a trace. Store display and decrease INTENSITY again.

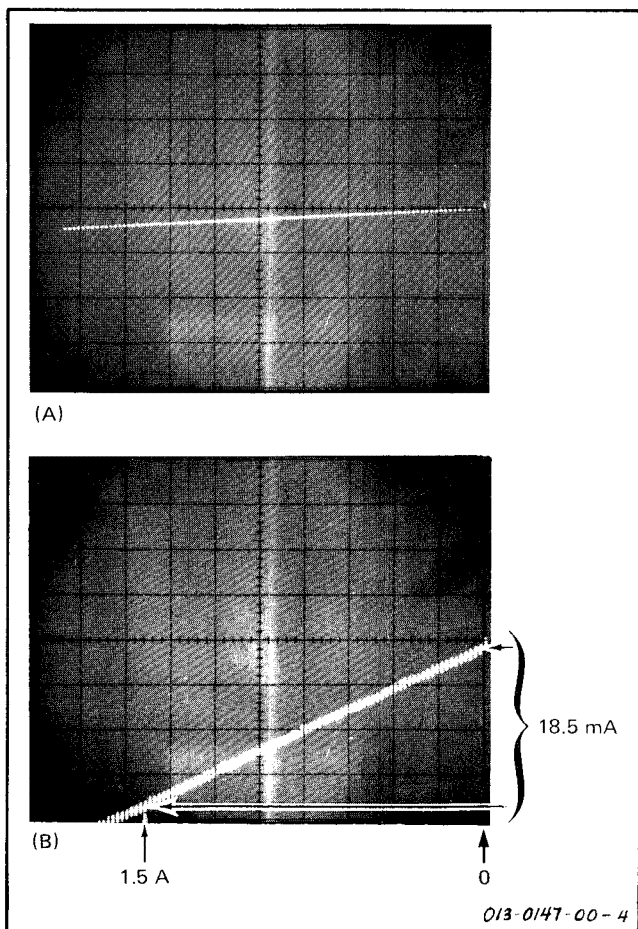

Fig. 2-8. Illustration of Example 1, part h.

NOTE

The first division to the left of the display start is 5 mA (.5 mA per step times 10 steps) and is the lower specified limit. Measure the difference between the 5 mA and 1.5 mA positions (vertically) to determine output regulation.

Note that regulation can be seen over the entire operating range rather than just at the points specified.

k. Turn INTENSITY down and erase the display.

l. Reset STEP/OFFSET AMPL to 10 mA.

m. Turn INTENSITY clockwise to produce a display. Store the display and turn INTENSITY down.

n. Check the display from 2.5 horizontal divisions to 7.5 horizontal divisions (250 mA to 750 mA). Again, read the regulation from the difference in vertical deflection between the 2.5 division and 7.5 division points. See Fig. 2-9.

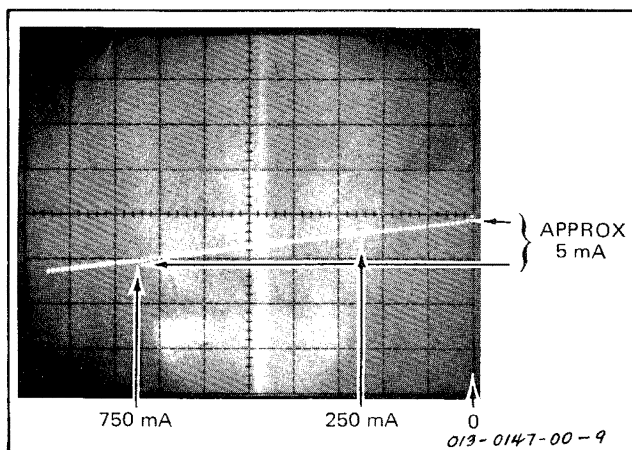

Fig. 2-9. Illustration of Example 1, part n.

2. LINE REGULATION

For a positive 5-volt regulator, such as the 7805C, having the following characteristics:

ELECTRICAL CHARACTERISTICS

(V IN =10 V and I OUT =500 mA)

Parameter	Conditions	Min	Typ	Max	Units
Output Voltage	T J 25°C	4.8	5.0	5.2	V
Line Regulation	T J 25°C	7 V ≤ V IN ≤ 25 V	3	100	mV
		8 V ≤ V IN ≤ 12 V	1	50	mV

a. Set the controls as follows:

577	
MAX PEAK VOLTS	100
MAX PEAK POWER-WATTS	100
VARIABLE COLLECTOR %	0
VARIABLE COLLECTOR % 0	
COLLECTOR SUPPLY POLARITY	+DC

All Dark Gray Buttons and Knobs In Except:

STEP/OFFSET POLARITY NORM	out (invert)
STEP FAMILY	SINGLE
PULSED 300 μ s	out
STEP/OFFSET AMPL	100 mA
NUMBER OF STEPS	1 (ccw)
HORIZ VOLTS/DIV	5 V, COLLECTOR

178

DUT SUPPLIES	OFF
+SUPPLY	25 V
-SUPPLY	TRACK +SUPPLY
SWEEP FREQUENCY	.1 Hz
SWEEP AMPLITUDE	0
FUNCTION	LINE REGULATION
VERT UNITS/DIV	50 mV

Regulator Test Unit

SUPPLY VOLTAGE Range	0-30
OUTPUT VOLTAGE COMPARISON Range	0-10
OUTPUT VOLTAGE COMPARISON Dial	\approx 5 V

b. If needed, place a compensating capacitor (value shown in regulator specification) on the Regulator Test Unit circuit board as shown in Fig. 2-5.

c. Plug the regulator into the adapter socket.

d. Press and hold the DISPLAY ZERO button and position the spot to left-center graticule, using vertical and horizontal POSITION controls. Release DISPLAY ZERO button.

e. Switch DUT SUPPLIES to ON. Press and hold Interlock Defeat button. Note that OVERLOAD lamp is lighted.

f. While holding Interlock Defeat button, increase VARIABLE COLLECTOR % until OVERLOAD lamp goes out.

g. Press BEAM FINDER button to determine approximate location of spot. Release BEAM FINDER. For all following steps, hold Interlock Defeat button in.

h. Adjust OUTPUT VOLTAGE COMPARISON dial to position spot vertically to graticule center. Note that spot is at fifth major division (25 volts) from zero (left).

i. Press PULSED 300 μ s and STEP FAMILY REP buttons. Turn NUMBER OF STEPS to 10 (fully clockwise). If OVERLOAD lamp comes on, either increase or decrease VARIABLE COLLECTOR % until lamp goes out.

j. Turn VERT UNITS/DIV clockwise (more sensitive) until the tenth displayed spot (bottom) nearly goes off screen. Reposition the top spot to graticule center as necessary.

k. Decrease the NUMBER OF STEPS until six spots are displayed. The sixth spot (fifth step) is 500 mA (specified load for this device).

l. Set the SWEEP AMPLITUDE to midrange. It may be necessary to change the VERT UNITS/DIV switch to keep the left end of the display on screen. See Fig. 2-10.

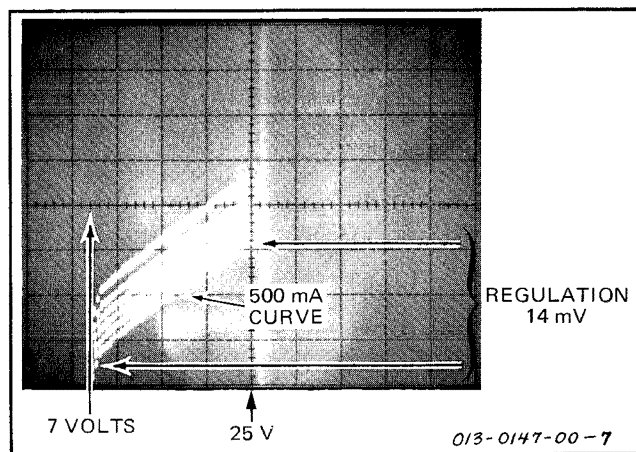

Fig. 2-10. Illustration of Example 2, part I.

m. Store the display and decrease the INTENSITY (ccw). Allow a few seconds to store one complete sweep.

n. Using the 500 mA (bottom) curve on the display, read the Line Regulation vertically between the 7 V (7 minor divisions from left) and 25 V (5 major divisions from left). If better resolution is needed at 7 volts, switch HORIZ VOLTS/DIV to 2 V or 1 V, COLLECTOR. Turn up INTENSITY to view display).

Operating Information—013-0147-00/013-0148-00

o. Reset +SUPPLY to 12 V, HORIZ VOLTS/DIV to 2 V, COLLECTOR, and SWEEP FREQUENCY VARIABLE counterclockwise to about midrange (≈ 0.05 Hz). Turn INTENSITY down and erase the display.

p. Turn up INTENSITY and allow one full sweep to be stored. Turn down INTENSITY.

q. Using the 500 mA (bottom) curve on the display, read Line Regulation vertically between the 8 V (4 major divisions from left) and 12 V (6 major divisions from left).

3. QUIESCENT OR COMMON CURRENT

For a positive 5-volt regulator, such as the 7805C, having the following characteristics:

ELECTRICAL CHARACTERISTICS

(V IN =10 V and I OUT =500 mA)

Parameter	Conditions	Min	Typ	Max	Units
Quiescent Current	T J 25°C		4.2	8.0	mA
Quiescent Current	with line 7 V \leq V IN \leq 25 V			1.3	mA
Current Change	with load 5 mA \leq I OUT \leq 1.0 A			0.5	mA

a. Set the controls as follows:

577

MAX PEAK VOLTS 25
 MAX PEAK POWER-WATTS 100
 VARIABLE COLLECTOR 100
 COLLECTOR SUPPLY POLARITY +DC

CHECK COMMON-TERMINAL (QUIESCENT) CURRENT

b. Place a compensating capacitor (value shown in Regulator specification) on the Regulator Test Unit circuit board as shown in Fig. 2-5.

c. Plug the regulator into the adapter socket.

All Dark Gray Buttons and Knobs In Except:

STEP/OFFSET POLARITY NORM out (invert)
 STEP FAMILY SINGLE
 STEP/OFFSET AMPL 100 mA
 Pulsed 300 μ s out
 NUMBER OF STEPS 1 (ccw)
 HORIZ VOLTS/DIV STEP GEN

d. Switch DUT SUPPLIES to ON.

e. Press and hold DISPLAY ZERO button while positioning the spot to right-center graticule, using the vertical and horizontal POSITION controls. Release DISPLAY ZERO button.

178

DUT SUPPLIES OFF
 +SUPPLY 10 V
 -SUPPLY TRACK +SUPPLY
 FUNCTION 1 COMMON
 VERT UNITS/DIV 5 mA
 Sweep Amplitude 0

f. Push PULSED 300 μ s and STEP FAMILY REP buttons.

g. Turn the NUMBER OF STEPS control clockwise until five steps (six spots) are displayed. See the typical display, Fig. 2-11.

Regulator Test Unit

SUPPLY VOLTAGE Range 0-30
 OUTPUT VOLTAGE COMPARISON Range 0-10
 OUTPUT VOLTAGE COMPARISON Dial 5 V

h. The quiescent current should be ≤ 8.0 mA (≤ 8 minor divisions of vertical deflection from the DISPLAY ZERO reference). 8.0 mA is the specified maximum current for this device.

CHECK COMMON-TERMINAL CURRENT (WITH LINE CHANGE)

i. Reset VARIABLE COLLECTOR % to 0, MAX PEAK VOLTS to 100, +SUPPLY to 25 V, VERT UNITS/DIV to 2 mA, and pull X10 VERT MAG.

j. Press and hold Interlock Defeat button and increase VARIABLE COLLECTOR % until +SUPPLY OVERLOAD lamp goes out. Using vertical POSITION control, position the sixth spot to bottom graticule line.

k. Store the display and slowly decrease the +SUPPLY dial to 7.0 volts. Decrease the display intensity.

l. The current (vertical display) at the fifth step (sixth line) should be ≤ 1.3 mA (≤ 6.5 major divisions of vertical deflection from bottom graticule line). 1.3 mA is the specified maximum current for this device. See Fig. 2-12.

CHECK COMMON-TERMINAL CURRENT CHANGE (WITH CHANGE IN LOAD)

m. Erase the display, increase intensity for normal display, and reset the controls as follows:

DUT SUPPLIES	OFF
MAX PEAK VOLTS	25
VARIABLE COLLECTOR %	100
STEP/OFFSET AMPL	200 mA
+SUPPLY	10 V
VERT UNITS/DIV	1 mA
X10 VERT MAG	pull
NUMBER OF STEPS	6 (7 spots)

n. Switch DUT SUPPLIES to ON.

o. Adjust the display to center screen using the vertical POSITION control. Adjust the NUMBER OF STEPS to display seven spots. Press to release STEP X.1 to out position.

p. Store the display. Measure the change in vertical deflection from 5 mA (see Fig. 2-13) to 1.0 A (five divisions from right at 200 mA/Div). Maximum current change (vertical) ≤ 0.5 mA (five divisions at .1 mA/Div).

NOTE

If more horizontal resolution is needed to read 5 mA, set the STEP/OFFSET AMPL to 0.5 mA and read the vertical deflection at 1 horizontal division from right graticule.

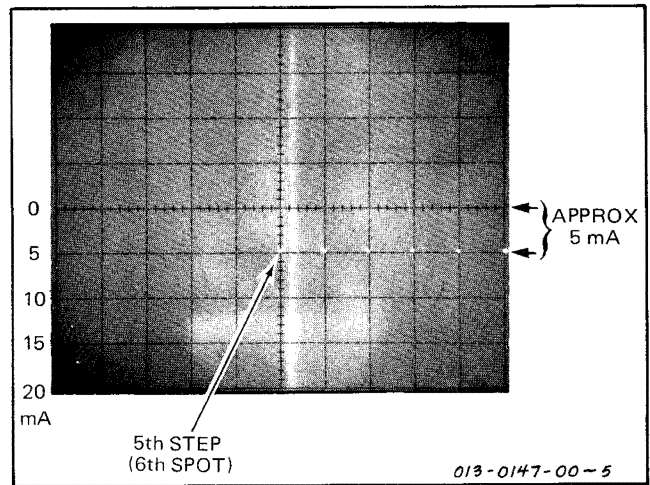

Fig. 2-11. Illustration of Example 3, part g.

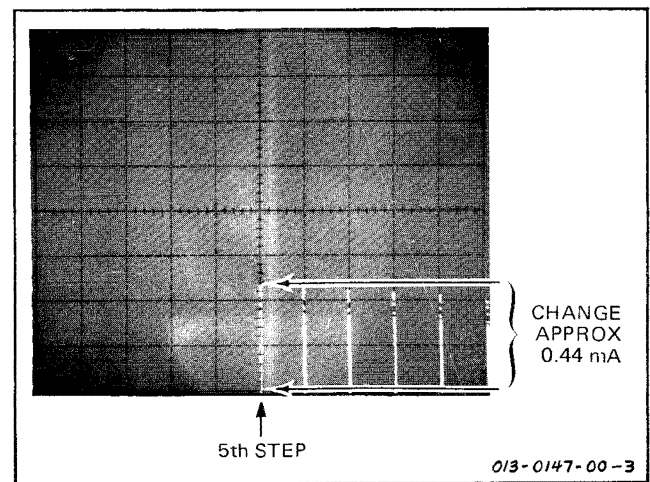

Fig. 2-12. Illustration of Example 3, part l.

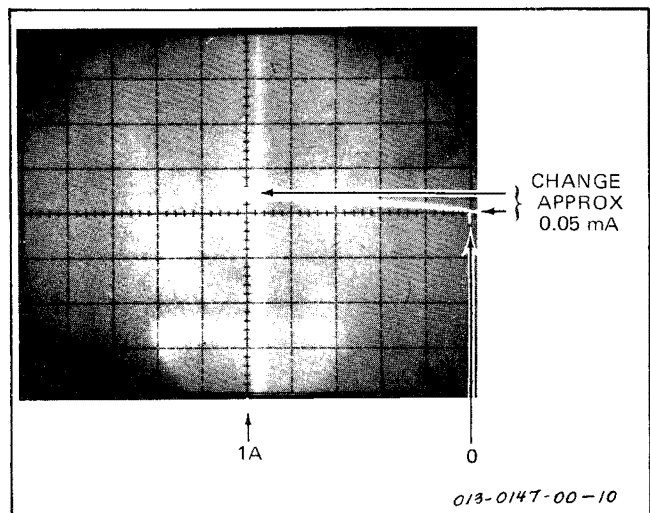

Fig. 2-13. Illustration of Example 3, part p.

APPLICATIONS

(Also see preceding examples, 1, 2, and 3)

RIPPLE REJECTION TEST

For a positive 5-volt regulator, such as the 7805C, having the following characteristics:

ELECTRICAL CHARACTERISTICS

(V IN 10 V, I OUT 500 mA, and T 25°C)

Parameter	Conditions	Min	Typ	Max	Units
Ripple Rejection	$8\text{ V} \leq V_{IN} \leq 18\text{ V}$			8	mV

a. Install an output compensating capacitor (if needed) on the Regulator Test Unit circuit board as shown in Fig. 2-5. The capacitor value is given in the regulator specification. Plug the Regulator Test Unit into the 178, the adapter into the Regulator Test Unit and the DUT into the adapter.

Regulator Test Unit

SUPPLY VOLTAGE Range 0-30
 OUTPUT VOLTAGE
 COMPARISON Range 0-10
 OUTPUT VOLTAGE
 COMPARISON Dial 5.00 V

b. Set the controls as follows:

577

MAX PEAK VOLTS 100
 MAX PEAK POWER-WATTS 100
 VARIABLE COLLECTOR % 0
 COLLECTOR SUPPLY POLARITY +DC

c. Press and hold DISPLAY ZERO button while positioning the spot to left-center graticule, using vertical and horizontal POSITION controls. Release DISPLAY ZERO button. Switch DUT Supplies to ON. Press and hold Interlock Defeat button. Increase VARIABLE COLLECTOR % until OVERLOAD lamp goes out.

d. Press and hold Interlock Defeat button for the remainder of the test. Press BEAM FINDER button to locate spot position (if off screen above or below graticule).

All Dark Gray Buttons and Knobs in Except:

STEP/OFFSET POLARITY NORM out (invert)
 STEP FAMILY SINGLE
 STEP/OFFSET AMPL 100 mA
 NUMBER OF STEPS 5 (six spots)
 PULSED 300 μs in
 HORIZ VOLTS/DIV 2 V, COLLECTOR

e. Adjust OUTPUT VOLTAGE COMPARISON dial to vertically position the spot to graticule center. Vertically position the spot to the first graticule division from the top, using the vertical POSITION control.

178

DUT SUPPLIES OFF
 +SUPPLY 18 V
 -SUPPLY TRACK +SUPPLY
 SWEEP AMPLITUDE 0
 SWEEP FREQUENCY 1 kHz
 VARIABLE 1/8 of full scale (approx 120 Hz)
 FUNCTION LINE REGULATION
 VERT UNITS/DIV 2 mV

f. Set STEP FAMILY to REP. Store the display.

g. Adjust SWEEP AMPLITUDE for a horizontal display from 8 to 18 volts, as shown in Fig. 2-14. This is a sampled display and takes several seconds to store a complete display.

h. Adjust NUMBER OF STEPS, if necessary, for 5 steps (six loops). If NUMBER OF STEPS is adjusted, erase and store again.

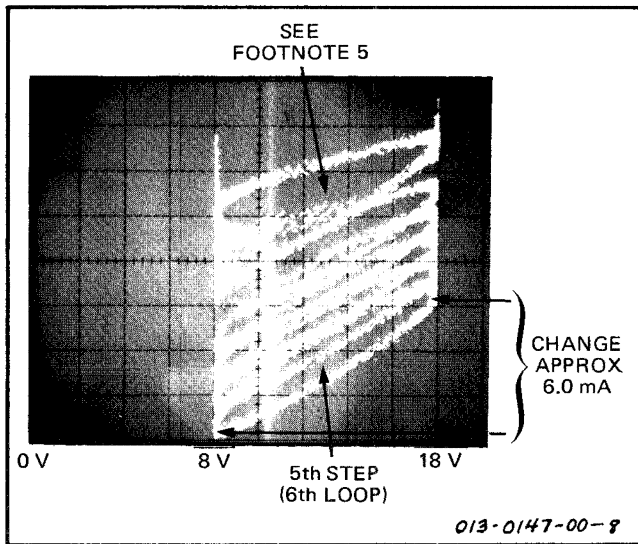

Fig. 2-14. Illustration of ripple rejection test, part g.

i. Observe the fifth step (sixth loop). Check that the maximum vertical deflection of the sixth loop is not greater than 8 mV (four major divisions).⁵

NOTE

If the SWEEP FREQUENCY controls are set precisely at 120 Hz, the display is six stationary spots. At 119 Hz, on sixth line, the display is traced once each second.

⁵The distorted loops, two top curves, in the illustration are the result of low load current. When the supply is swept, C665 can not discharge fast enough, at the 120 Hz sweep frequency, when Q678 turns off. Q644 provides about 25 mA of discharge current, but is inadequate at low loads. This condition can be corrected by connecting a resistor between the Regulator Test Unit INPUT terminal and GND (on the 178 front panel) to provide the extra current. This load resistor has no effect on the measurement, made on the sixth loop.

DROPOUT VOLTAGE TEST

For a positive 5-volt regulator, such as the 7805C, having the following characteristics:

ELECTRICAL CHARACTERISTICS

(V IN 10 V, I OUT 1 A, and T J 25°C)

Parameter	Conditions	Min	Typ	Max	Units
Output Voltage	$7 V \leq V_{IN} \leq 20 V$	4.75		5.25	Volts

a. Install an output compensating capacitor (if needed) on the Regulator Test Unit circuit board as shown in Fig. 2-5. Capacitor value is given in the regulator specification. Plug the Regulator Test Unit into the 178, the adapter into the Regulator Test Unit, and the regulator into the adapter.

b. Set the controls as follows:

	577
MAX PEAK VOLTS	100
MAX PEAK POWER-WATTS VARIABLE	100
COLLECTOR %	0
COLLECTOR SUPPLY POLARITY	+DC

All Dark Gray Buttons and Knobs In Except:

STEP/OFFSET	
POLARITY NORM	out (invert)
STEP FAMILY	SINGLE
STEP/OFFSET AMPL	100 mA
NUMBER OF STEPS	1 (ccw)
PULSED 300 μ x	in
HORIZ VOLTS/DIV	2 V, COLLECTOR

178

DUT SUPPLIES	OFF
+SUPPLY	20 V
-SUPPLY	TRACK +SUPPLY
SWEEP AMPLITUDE	0
SWEEP FREQUENCY	1 Hz
VARIABLE	X1
FUNCTION	LINE REGULATION
VERT UNITS/DIV	50 mV

Operating Information—013-0147-00/013-0148-00

Regulator Test Unit

SUPPLY VOLTAGE Range 0-30

OUTPUT VOLTAGE

COMPARISON Range 0-10

OUTPUT VOLTAGE

COMPARISON Dial 5.00 V

c. Press and hold DISPLAY ZERO button while positioning the spot to left-center graticule, using vertical and horizontal POSITION controls. Release DISPLAY ZERO button.

d. Switch DUT SUPPLIES to ON. Press and hold Interlock Defeat button for the remainder of the test. Increase VARIABLE COLLECTOR % until OVERLOAD lamp goes out.

e. Press BEAM FINDER button to locate spot position (if off screen above or below graticule).

f. Adjust OUTPUT VOLTAGE COMPARISON dial to vertically position the spot to graticule center. Vertically position the spot to the first division from the top, using the vertical POSITION control.

g. Set STEP FAMILY to REP. Turn NUMBER OF STEPS to 10. Store the display.

h. Adjust SWEEP AMPLITUDE for a 6-volt to 20-volt horizontal display (three divisions to 10 divisions) as shown in Fig. 2-15. This is a sampled display and takes several seconds to store the complete display.

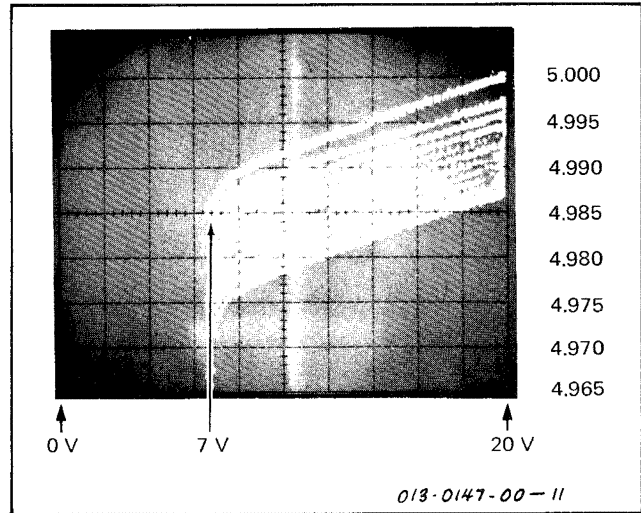

Fig. 2-15. Illustration of dropout voltage test, part h.

i. Observe the area between 7.0 volts and 20 volts. Check that the minimum output voltage is greater than 4.75 volts (on vertical). Check that maximum output voltage is less than 5.25 volts (on vertical), over the operating range.

NOTE

Typically, dropout voltage should occur at a level less than "minimum output voltage for a given load current value", plus two volts.

CIRCUIT DESCRIPTION

GENERAL

This description explains the theory of operation of the Positive Regulator Test Unit. The Negative Regulator Test Unit description is identical to that of the positive unit except as shown in Table 3-1. Component numbers on the Regulator Input Supply card are 600-series for the +Supply card and 700-series for the -Supply card.

See schematic diagrams, 1, 2, 3, and Fig. 3-1.

TABLE 3-1

Supply or Switch Position	+Regulator Supply Card	-Regulator Supply Card
V X	-30 V	+30 V
V Y	+30 V	-30 V
V Z	-6.2 V	+6.2 V
COLLECTOR SUPPLY POLARITY	+DC	-DC

The Regulator Test Unit consists of the following circuits: Regulator Input Supply, Output Voltage Comparison, DUT Output Buffer, Common-Terminal Current, Internal Op-Amp Supplies, and Display Positioning (horizontal).

REGULATOR INPUT SUPPLY

A prime function of the Regulator Supply card is regulating the Collector Supply (from the 577 via Regulator Test Unit edge connector terminals A3 and B2, to Regulator Supply card edge connector, terminal 10).

Q650-Q660 (a differential-input comparator) compares the +DUT SUPPLY voltage from the 178 (A19) with the voltage at Q676-Q678 collectors (DUT INPUT terminal).

Current in Q650, through R654, determines Q676-Q678 drive. If all of the Q655 (current source) current flows in Q650, the circuit goes out of regulation. This condition can occur if Q676-Q678 output is short circuited.

In this short-circuited condition, Q660 turns off, turning Q648 off. When Q648 turns off, V X (-30 volts) through R646 and emitter follower, Q645, pulls the +DUT SUPPLY toward ground. When more than approximately 20 mA is drawn from the +DUT SUPPLY, the +SUPPLY OVERLOAD lamp on the 178 lights, indicating that the supply is overloaded. The +SUPPLY OVERLOAD current is set by R637.

Triac Q672 and VR674-R674 prevent the Collector Supply from rising above about +93 volts. If the Collector Supply rises above the 91-volt Zener (VR674) level (plus 2-volt gate voltage), the voltage drop across R674 turns Q672 on, grounding the Collector Supply to protect the Regulator Supply components and the DUT.

If the Collector Supply Polarity is set such that Regulator Input Supply terminal 10 goes negative, CR673 is reverse biased, preventing reverse-voltage component damage. In this reverse-polarity condition, VR674 is forward biased, turning Q672 on (if the Collector Supply remains in this reverse-polarity condition, the Collector Supply circuit breaker in the 577 opens). The Collector Supply voltage must be decreased to zero to turn Q672 off.

To assist the operator in setting the Collector Supply at least 12 volts above the DUT Input Supply voltage, the +SUPPLY OVERLOAD lamp serves as an indicator.

If the Collector Supply voltage is less than 12 volts above the DUT Input Supply voltage, Q645 turns on (through VR672, divider R625-R626-R627, switch S625, and CR645), lighting the +SUPPLY OVERLOAD lamp.

Another network, VR671-R671, prevents the Collector Supply voltage from going more than 40 V above the DUT Supply voltage (keeps Q678 within its power dissipation limits). If VR671-R671 draw current through R675, Q670 turns on, turning Q676-Q678 off, which, in turn, takes the loop out of regulation. Q650 draws all of the current available from Q655, Q648 turns off, Q645 turns on, and the +SUPPLY OVERLOAD lamp lights.

The Regulator Input Supply voltage range can be doubled by grounding terminal 1 (Regulator Input Supply card edge connector) through contacts in S625. The voltage at INPUT SENSE terminal is applied to Q660 base from R661-R662 junction, causing the Input Voltage range to double (provides two voltage ranges: 0-30 V and 0-60 V).

Q670, with R677, limit output current. If the voltage drop across R677 reaches about 700 mV, Q670 turns on, raising Q676 base, limiting output current, and the +SUPPLY OVERLOAD lamp lights.

S670 is a thermal cutout switch mounted on the chassis with Q676-Q678, Q672, Q664, Q642, and Q644. The cutout opens at 100°C and is indicated by the +SUPPLY OVERLOAD lamp. The thermal cutout closes when the

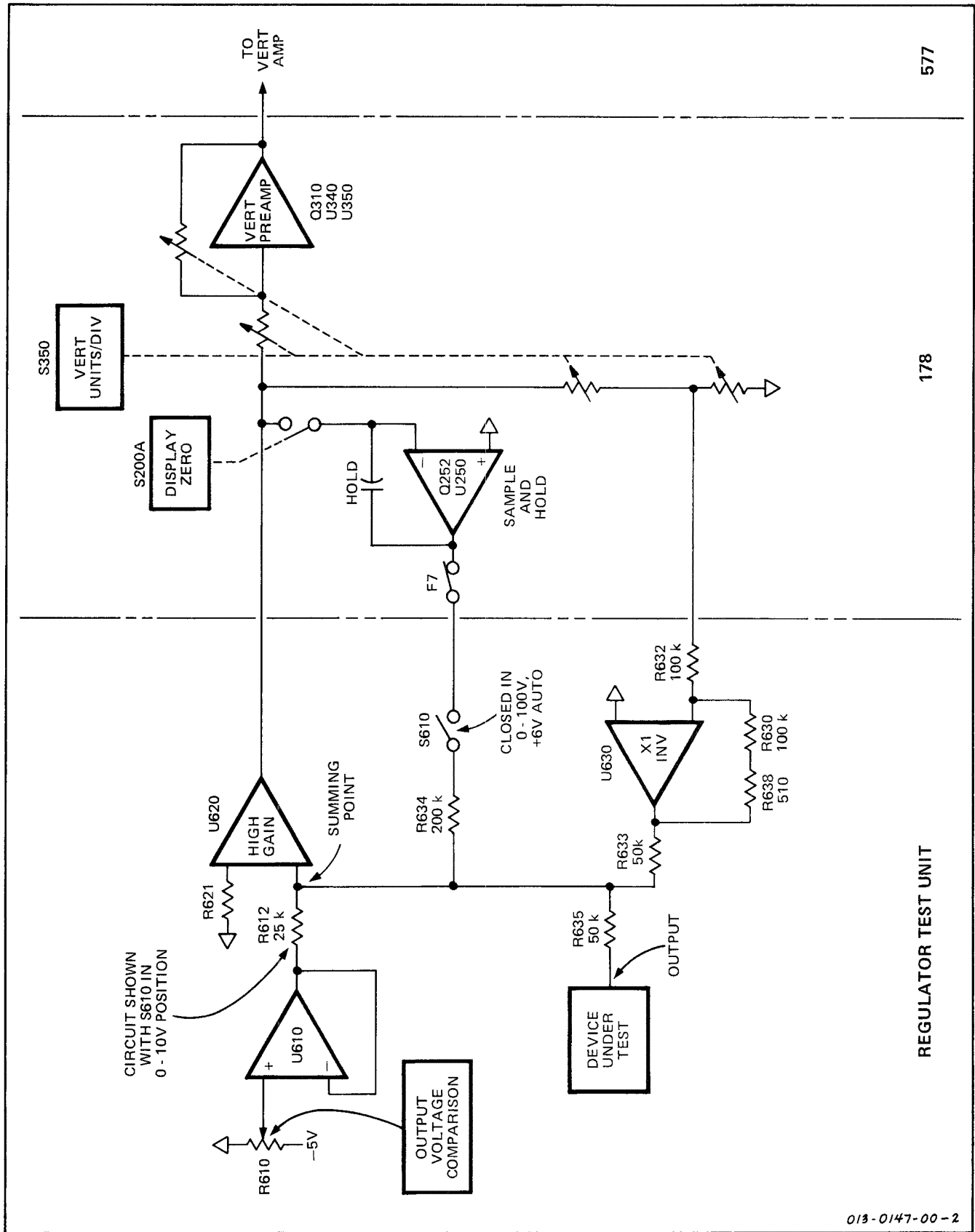

Fig. 3-1. Voltage Comparison circuit block diagram.

chassis temperature decreases to approximately 88°C (usually three minutes or more with no load current).

Q664-R665 is a bias current source that provides about 25 mA of bias to Q676-Q678 so that the supply regulates when little or no load current is being drawn.

OUTPUT VOLTAGE COMPARISON

This circuit consists of a calibrated supply, a non-inverting, high-gain amplifier, a divider (in the 178) and a unity-gain inverting feedback amplifier. See Fig. 3-1.

The high-gain, non-inverting amplifier (U620), the divider, and the inverting amplifier (U630), are a feedback loop with the summing point at U620 input. U620 output is fed to the 178-577 vertical deflection amplifier.

The DUT output voltage is connected through R635 to the summing point.

The calibrated voltage supply also connected to the summing point, offsets the DUT output dc level (at the summing point) to position the display on the crt graticule.

S610 provides two offset voltage ranges, 0-10 V and 0-100 V. In addition, S610 provides a 0-100-volt range that automatically positions the display zero to graticule center when the DISPLAY ZERO button is pushed, if the OUTPUT VOLTAGE COMPARISON dial is within ± 6 volts of the DUT output voltage.

As an example: In the 0-10-volt range, with a 5-volt regulator in the test socket, and the OUTPUT VOLTAGE COMPARISON dial set to 5.0, U610 output is -2.5 volts and U620 input is zero (due to the resistance ratio of R612-R635).

Any voltage change at the DUT output is fed to the input of U620, amplified, applied to the divider in the 178 (part of the VERT UNITS/DIV switch), inverted by U630, and fed back to U620 input (the summing point). The change at U630 output is equal and opposite to the change at the DUT output. Therefore, the voltage change at the summing point is essentially zero.

The deflection caused by the change in DUT output voltage is determined by the VERT UNITS/DIV switch setting in the 178).

With S610 in the 0-100 V, ± 6 V AUTO position and the OUTPUT VOLTAGE COMPARISON dial set to a dc

voltage within ± 6 V of the DUT output voltage, the voltage input is not at exactly zero. The amplification of U620 produces an output (U620) voltage that causes the display to be off screen.

Pushing the DISPLAY ZERO button charges the Hold capacitor (in the Sample and Hold circuit in the 178) from U620 output. The Sample and Hold circuit, fed to the Voltage Comparison summing point via S610-R634, pulls the summing point to zero, bringing the display to graticule center. The charge on the Hold capacitor holds U620 input level at zero, holding the display at graticule center.

OUTPUT BUFFER

This circuit provides either a dc, a stepped, or a pulsed current-load for the DUT.

The load is provided by the step generator in the 577. The step-generator load is applied to the DUT output through buffer Q642-Q644 (a Darlington configuration). This buffer gives the Step Generator compliance in the 0-60-volt range that the DUT can go through.

COMMON-TERMINAL CURRENT

The common-terminal circuit (Q640-U615) provides an artificial ground for the DUT while measuring common-terminal current.

Q640-U615 is a feedback amplifier configuration with the DUT common terminal as the summing point (virtual ground). Q640, a Darlington configuration prevents current error in the measurement circuit caused by base current.

Q640 collector current (common-terminal current) is measured in the 178 on the $-$ DUT SUPPLY lead (A17 on the Regulator Test Unit edge connector) when the positive regulator unit is used. When the negative regulator unit is used, the common terminal current is measured on the positive DUT SUPPLY lead (A19 on the Regulator Test Unit edge connector).

INTERNAL VOLTAGE SUPPLIES

VR638 and VR639 provide the -10 -volts and $+10$ -volts for the integrated circuit operational amplifiers on the Regulator Test Unit.

Supply V_Z is derived from the 30-volt supply via VR647 and R647. See Table 3-1.

Supplies V_X and V_Y are connected to the 30-volt supplies as shown in Table 3-1.

Circuit Description—013-0147-00/013-0148-00

DISPLAY POSITIONING

Relay K601 is controlled by contacts in the 178 FUNCTION switch to automatically position the display

zero horizontally, either to the left or right of the crt graticule, depending on the test being made (FUNCTION switch position).

MAINTENANCE

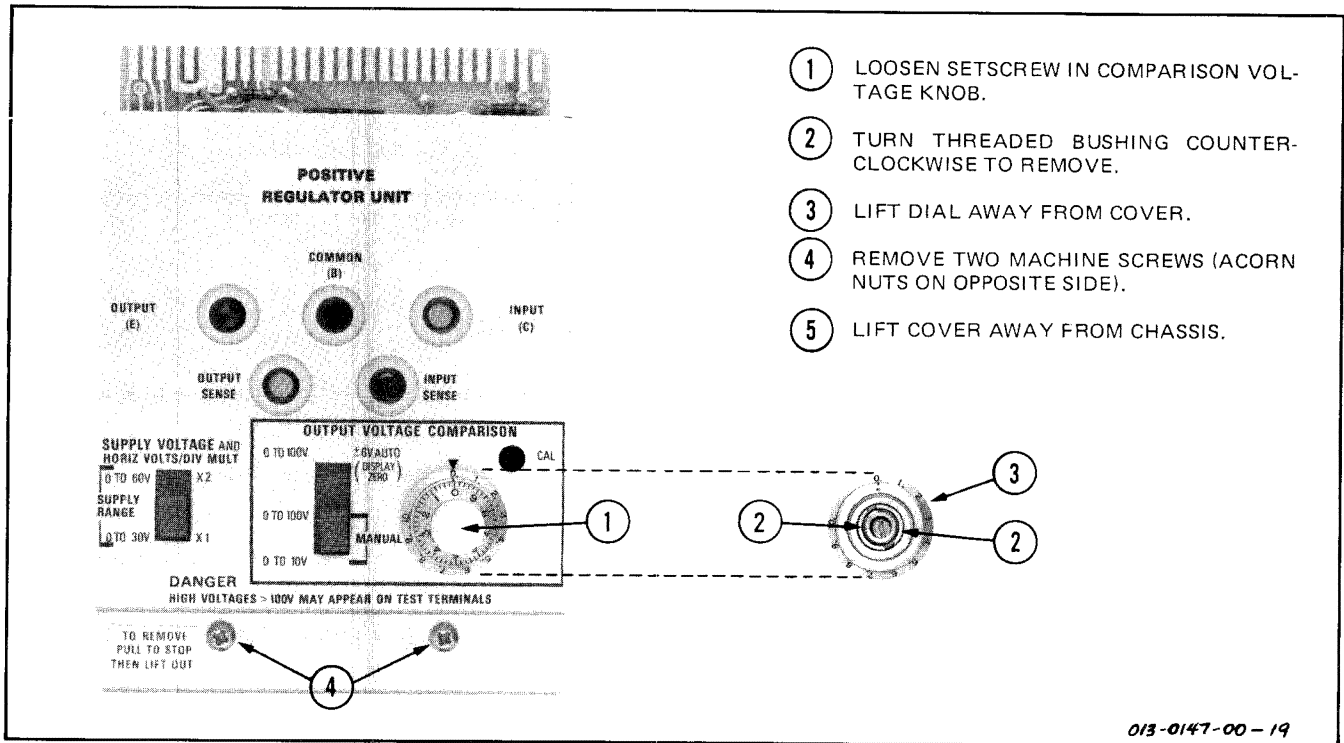

Fig. 4-1. Top-panel removal.

GENERAL

Follow the general maintenance procedures outlined in the 178 Instruction Manual.

TOP PANEL REMOVAL

See Fig. 4-1 for top-panel removal instructions.

INPUT REGULATOR SUPPLY CARD REMOVAL

To remove the plug-in Input Regulator Supply card from the Regulator Test Unit, follow the removal procedure in Fig. 4-2.

HEAT SINK (INPUT REGULATOR SUPPLY CARD) REMOVAL

See Fig. 4-3 for heat sink removal.

OUTPUT VOLTAGE COMPARISON DIAL MECHANICAL POSITION

Refer to Step 1 and footnote 3, of the Performance Check, Section 5, for mechanical adjustment of the Comparison dial.

TROUBLESHOOTING AIDS

Table 2-2 (in the Operating Information, Section 2) shows conditions that light the OVERLOAD lamps and which lamps are lighted for each condition.

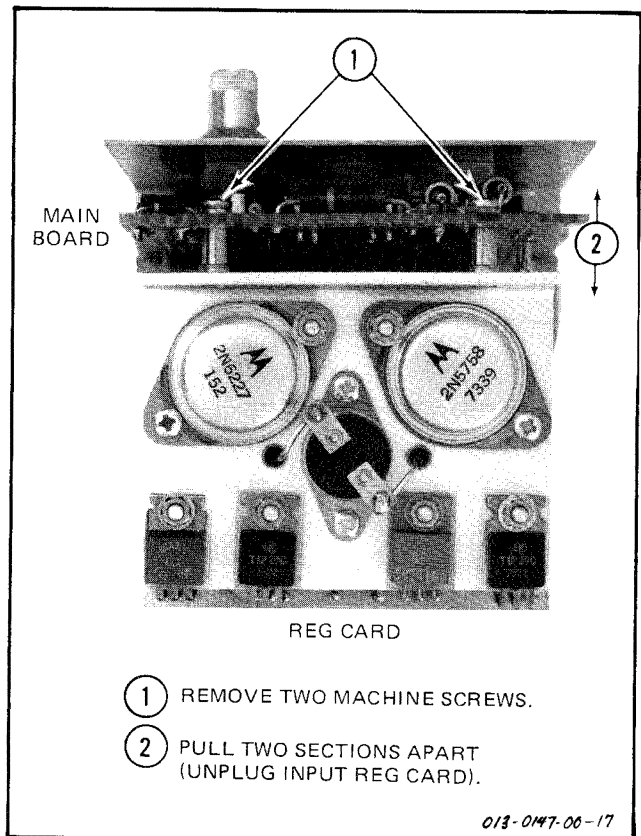

Fig. 4-2. Input Regulator Supply card removal.

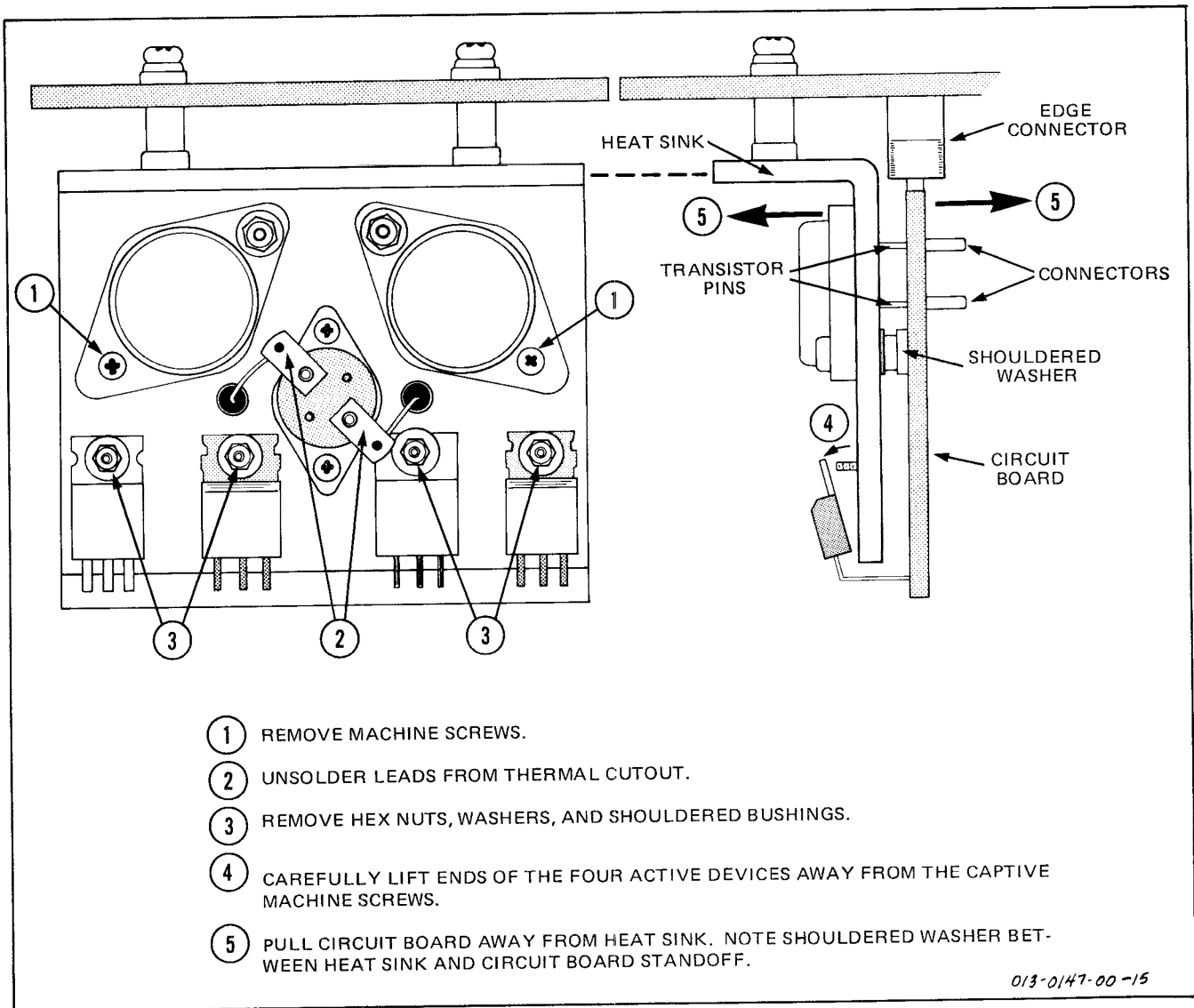

Fig. 4-3. Input Regulator Supply card heat-sink removal.

PERFORMANCE CHECK PROCEDURE

INTRODUCTION

The only adjustment on the Regulator Test Unit is a measurement accuracy adjustment. See Step 1, part j.

TEST EQUIPMENT REQUIRED

The following test equipment, or equivalent, is required for a complete check of the Regulator Test Unit. All test equipment is assumed to be correctly calibrated and operating within the listed specifications.

1. Calibrated 577-D1.
2. Calibrated 178.
3. Digital Voltmeter. 4 1/2 digits; voltage range, 0-60 V; accuracy, 0.1%; input impedance, 10 M Ω .
4. Resistor¹. 100 Ω , $\pm 1/4\%$.
5. Resistor¹. 1 k Ω , $\pm 1/4\%$.
6. Resistor¹. 10 k Ω , $\pm 1/4\%$.
7. Patch cords. Two six-inch, and one twelve-inch, banana-banana. One two-inch, 40-mil pin (same as supplied with the Standard Op Amp Test Unit).
8. Miscellaneous. Alligator and banana-plug adapters.

PERFORMANCE CHECK

NOTE

This procedure is written for the Positive Regulator Test Unit. For Negative Regulator Test Units, where opposite polarities or display positions are required, the setting or step is marked to indicate the change.

The procedure is arranged to permit starting at any point. Each new step has a complete listing of control settings. When using the complete procedure, change only those controls that are set in bolder type face.

¹This resistor is included in the resistor kit (Tektronix Calibration Fixture, 067-0691-00) needed to calibrate the 177 and 178.

1. CHECK COMPARISON VOLTAGE DIAL ACCURACY, 0-10 VOLT RANGE

a. With DUT SUPPLIES switch OFF, set the controls as follows:

577

MAX PEAK VOLTS	25
MAX PEAK POWER-WATTS	100 ²
VARIABLE COLLECTOR %	100
COLLECTOR SUPPLY POLARITY	+DC (–DC for Negative Test Units)

All Dark Gray Buttons and Knobs in Except:

STEP FAMILY	SINGLE
STEP/OFFSET	
POLARITY NORM	out (invert)
PULSED 300 μ s	out
HORIZ VOLTS/DIV	STEP GEN

178

+SUPPLY	5 V
–SUPPLY	TRACK +SUPPLY
SWEEP AMPLITUDE	0
SWEEP FREQUENCY	1 kHz
FUNCTION	LOAD REGULATION
VERT UNITS/DIV	50 mV

Regulator Test Unit

SUPPLY VOLTAGE Range	0-30
OUTPUT VOLTAGE	
COMPARISON Range	0-10
OUTPUT VOLTAGE	
COMPARISON Dial	≈ 0.5 V

b. Using a short banana-banana patch cord, connect INPUT terminal to OUTPUT terminal.

c. Connect DVM between OUTPUT SENSE and GND (on the 178 front panel). Switch DUT SUPPLIES to ON.

d. Set +SUPPLY dial as close as possible to 0.500 volts on DVM.

²Fourteen resistor values are coupled to the MAX PEAK VOLTS switch to maintain one of six labeled peak-power limits. The SERIES RESISTORS and PEAK POWER-WATTS switch pulls out to unlock from the MAX PEAK VOLTS switch. For this procedure, leave the MAX PEAK POWER-WATTS at 100-switch only the MAX PEAK VOLTS and the SERIES RESISTOR value changes to maintain the power relationship.

Performance Check—013-0147-00/013-0148-00

e. Press and hold DISPLAY ZERO button while vertically and horizontally positioning spot to, or near to, crt graticule center. Use this spot position as a reference for the following checks.

f. Set VOLTAGE COMPARISON dial to exactly 0.5.

g. CHECK—Read accuracy on graticule (spot distance from reference, in divisions, times vertical units per division). Maximum, within 25 mV ($\pm 1\%$ of DVM reading, ± 20 mV)³. For better resolution, reset VERT UNITS/DIV to 10 mV.

h. Set +SUPPLY dial for as close as possible to 9.000 volts on DVM. Press DISPLAY ZERO button.

i. Set VOLTAGE COMPARISON dial to exactly 9.0. Reset VERT UNITS/DIV to 50 mV and press DISPLAY ZERO button.

j. CHECK—Read accuracy on graticule (spot distance from reference, in divisions, times vertical units per division). Maximum, within 110 mV ($\pm 1\%$ of DVM reading, ± 20 mV). For better resolution, reset VERT UNITS/DIV to 10 mV. If needed, adjust the OUTPUT VOLTAGE COMPARISON CAL to the DISPLAY ZERO reference. If an adjustment is made, repeat parts d through j.

2. CHECK COMPARISON VOLTAGE DIAL ACCURACY, 0-100-VOLT RANGE

With DUT SUPPLIES switch OFF,

a. Reset controls as follows:

	577
MAX PEAK VOLTS	100
MAX PEAK POWER-WATTS	100 ²
VARIABLE COLLECTOR %	80
	178
VERT UNITS/DIV	50 mV
+SUPPLY Dial	30 V

²ibid

³If the OUTPUT VOLTAGE COMPARISON dial does not meet accuracy specifications, or if the dial has been removed and replaced, calibrate as follows: With the DVM connected between OUTPUT SENSE and GND, adjust the +SUPPLY control to give a 0.500 volt reading on the DVM. Adjust the OUTPUT VOLTAGE COMPARISON dial to position the spot vertically to the DISPLAY ZERO reference on the crt. Loosen the dial setscrew and mechanically set the dial to 0.5. Tighten the setscrew and recheck.

REGULATOR TEST UNIT

SUPPLY VOLTAGE Range 0-60
**OUTPUT VOLTAGE
 COMPARISON Range** 0-100
**OUTPUT VOLTAGE
 COMPARISON Dial** ≈ 60 V
 DUT SUPPLIES Switch ON

b. Set +SUPPLY dial as close as possible to 60 volts (30 on dial. +SUPPLY output doubled with SUPPLY VOLTAGE Range at 0-60). Press and hold Interlock Defeat button (note that +OVERLOAD lamp goes out. If not, decrease VARIABLE COLLECTOR % while alternately pressing and releasing Interlock Defeat button until lamp is out with Interlock Defeat button in).

c. Set +SUPPLY to read 50.00 on DVM. Press DISPLAY ZERO button to check reference. Set OUTPUT VOLTAGE COMPARISON dial to position the spot to reference.

d. CHECK—Read accuracy from OUTPUT VOLTAGE COMPARISON dial (in 100-volt range, each minor dial division = 200 mV. Read 50 V, $\pm 1\%$, ± 150 mV (± 650 mV or 3.25 minor dial divisions)).⁴

e. Reset MAX PEAK VOLTS to 25 and VARIABLE COLLECTOR % to 100.

f. Set +SUPPLY as close as possible to 5.000 volts on DVM (2.5 on +SUPPLY dial). Press DISPLAY ZERO to check reference.

g. Set OUTPUT VOLTAGE COMPARISON dial to position spot to reference (≈ 0.5 on VOLTAGE COMPARISON Dial).

h. CHECK—Read accuracy from OUTPUT VOLTAGE COMPARISON dial. Read 5 volts, $\pm 1\%$, ± 150 mV (± 200 mV, or 1 minor dial division).

3. CHECK VOLTAGE COMPARISON DIAL ACCURACY, 0-100 V, ± 6 V AUTO

a. Reset +SUPPLY to ≈ 12 V on DVM.

b. Set OUTPUT VOLTAGE COMPARISON dial 6 volts above the DVM reading (approximately 18 volts on dial). Note that there is no spot on screen.

⁴Can be adjusted with OUTPUT VOLTAGE COMPARISON CAL. See step 1, part j.

c. Press the DISPLAY ZERO button to check the reference.

d. Move OUTPUT VOLTAGE COMPARISON Range switch to 0-100 V, ± 6 V AUTO.

e. CHECK—Press the DISPLAY ZERO button and note that the spot returns and remains at reference.

f. Reset OUTPUT VOLTAGE COMPARISON dial 6 volts below the DVM reading (approximately 6 volts). Note that there is no spot on screen.

g. CHECK—Press the DISPLAY ZERO button and note that the spot returns to and remains at zero reference.

h. Connect the DVM between front-panel EXT SIGNAL IN and GND.

i. CHECK—Read the same voltage (12 volts) as previously read between OUTPUT SENSE and GND (part a).

j. Remove patch cords and DVM.

4. CHECK LOAD ACCURACY

a. With DUT SUPPLIES switch OFF, set controls as follows:

577

MAX PEAK VOLTS	100
MAX PEAK	
POWER-WATTS	100 ²
VARIABLE	
COLLECTOR %	80
COLLECTOR SUPPLY	+DC (–DC for Negative
POLARITY	Test Units)

All Dark Gray Buttons and Knobs In Except:

STEP FAMILY	SINGLE
STEP/OFFSET INVERT	
NORM	out (invert)
OFFSET ZERO	out
OFFSET AID	in
STEP/OFFSET AMPL	1 mA
OFFSET MULT	5.0
PULSED 300 μ s	out

²ibid

Ⓐ

178

+SUPPLY	60 V
–SUPPLY	TRACK +SUPPLY
SWEEP AMPLITUDE	0
SWEEP FREQUENCY	1 kHz
FUNCTION	LINE REGULATION
VERT UNITS/DIV	50 mV

REGULATOR TEST UNIT

SUPPLY VOLTAGE Range	0-60 V
OUTPUT VOLTAGE	
COMPARISON Range	0-100, ± 6 V, AUTO
OUTPUT VOLTAGE	
COMPARISON Dial	60 V

b. Connect a 10 Ω , 1/4% resistor between GND and STEP GEN (178 front panel).

c. Connect DVM across 10 Ω resistor. Switch DUT SUPPLIES to ON.

d. Adjust OFFSET MULT for 0.050 volt on DVM. Switch DUT SUPPLIES to OFF.

e. Reconnect the 10 Ω resistor and DVM between INPUT and OUTPUT terminals. Switch DUT SUPPLIES to ON.

f. CHECK—Press Interlock Defeat button (on 178 front panel) and read 0.050 V, ± 12.5 mV on DVM.

g. Release Interlock Defeat button and disconnect resistor and DVM. Press DISPLAY ZERO button.

5. CHECK INPUT SUPPLY VOLTAGE ACCURACY

a. With DUT SUPPLIES switch OFF, set controls as follows:

577

MAX PEAK VOLTS	100
MAX PEAK	
POWER-WATTS	100 ²
VARIABLE	
COLLECTOR %	≈ 50
COLLECTOR SUPPLY	+DC (–DC for Negative
POLARITY	Test Unit)

All Dark Gray Buttons and Knobs In Except:

STEP FAMILY	SINGLE
STEP/OFFSET	
POLARITY NORM	out (invert)
PULSED 300 μ s	out
HORIZ VOLTS/DIV	5 V, COLLECTOR

178

+SUPPLY ≈ 30 V
−SUPPLY TRACK +SUPPLY
SWEEP AMPLITUDE 0
SWEEP FREQUENCY 1 kHz
FUNCTION **COLLECTOR SUPPLY**
VERT UNITS/DIV **50 mV**

REGULATOR TEST UNIT

SUPPLY VOLTAGE Range **0-30**
OUTPUT VOLTAGE
COMPARISON Range **0-100**
OUTPUT VOLTAGE
COMPARISON Dial ≈ 50 V

b. Connect DVM between INPUT and +SUPPLY (on front panel). For negative Test Unit, connect DVM between INPUT and −SUPPLY. Press and hold Interlock Defeat button (parts c through h) and read DVM.

c. CHECK—DVM reading, 0 V, ± 100 mV.⁵

d. Set +SUPPLY dial to ≈ 5.0 V and SUPPLY VOLTAGE Range to 0-60 V.

e. Connect DVM between +SUPPLY (−SUPPLY for Negative Test Unit) and GND.

f. Adjust +SUPPLY for 5.000 V on DVM.

g. Connect DVM between INPUT and GND.

h. CHECK—DVM reading 10 V, $\pm 0.5\%$, ± 100 mV (10 V, ± 150 mV).

i. Reset VARIABLE COLLECTOR % to 80 and +SUPPLY to 30.

j. Connect DVM between +SUPPLY (−SUPPLY for Negative Test Unit) and GND. Press and hold Interlock Defeat button. Adjust +SUPPLY for 30.00 on DVM.

k. Connect DVM between INPUT and GND. Press and hold Interlock Defeat button.

l. CHECK—DVM reading, 60 V, % ± 100 mV (60 V, ± 400 mV).

⁵If this specification can not be met, interchange Q650 and Q660 and recheck (Q750 and Q760 for Negative Regulator Test Unit).

6. CHECK OVERLOAD LAMP OPERATION

a. Reset controls as follows: VARIABLE COLLECTOR % to 0, +SUPPLY to 20 V, SUPPLY VOLTAGE Range, 0-30, and HORIZ VOLTS/DIV, 10 V, COLLECTOR. Horizontally position spot to left-center graticule lines (right-center graticule for Negative Test Unit).

b. Press and hold Interlock Defeat button. Increase VARIABLE COLLECTOR % until +OVERLOAD lamp just goes out.

c. CHECK—Read the voltage on crt, divisions of deflection from left graticule line (right graticule line for Negative Test Unit) times 10 volts per division. Read 31 to 35 volts (3.1 to 3.5 major divisions).⁶

d. Increase VARIABLE COLLECTOR % until +OVERLOAD lamp comes on.

e. CHECK—Read 60-70 volts on CRT (6 to 7 major graticule divisions).

7. CHECK OUTPUT REGULATION

a. With DUT SUPPLIES switch OFF, set controls as follows:

	577
MAX PEAK VOLTS	100
MAX PEAK POWER-WATTS	100 ²
VARIABLE COLLECTOR %	80
COLLECTOR SUPPLY POLARITY	+DC (−DC for Negative Test Unit)

All Dark Gray Buttons and Knobs In Except:

STEP/OFFSET POLARITY NORM	out (invert)
STEP FAMILY	SINGLE
STEP/OFFSET AMPL NUMBER OF STEPS	200 mA 10
PULSED 300 μ s	in
Horizontal POSITION	centered
Vertical POSITION	centered
HORIZ VOLTS/DIV	STEP GEN

³ibid

⁶In this test, the spot may have some horizontal dimension. If so, read from the left edge of the spot (right edge for Negative Test Unit).

	178	
+SUPPLY		30
-SUPPLY		TRACK +SUPPLY
FUNCTION		LOAD REGULATION
SWEEP FREQUENCY		.1 Hz
SWEEP AMPLITUDE		0
VERT UNITS/DIV		50 mV

REGULATOR TEST UNIT	
SUPPLY VOLTAGE Range	0-60
OUTPUT VOLTAGE	
COMPARISON Range	0-100, ±6 V AUTO
OUTPUT VOLTAGE	
COMPARISON Dial	≈60 V

b. Patch INPUT to OUTPUT. Patch INPUT SENSE to INPUT. Patch OUTPUT SENSE to OUTPUT.

c. Press DISPLAY ZERO button and position the spot to upper-right graticule lines (lower-left for Negative Test Unit) with vertical and horizontal POSITION controls. Switch DUT SUPPLIES to ON.

d. Press STEP FAMILY REP button.

e. Press and hold Interlock Defeat button and press and release DISPLAY ZERO button.

f. CHECK—Last spot on left (right for Negative Test Unit) is ≤250 mV (≤5 divisions) from the top graticule line. See Fig. 5-1.

g. Remove patch cords.

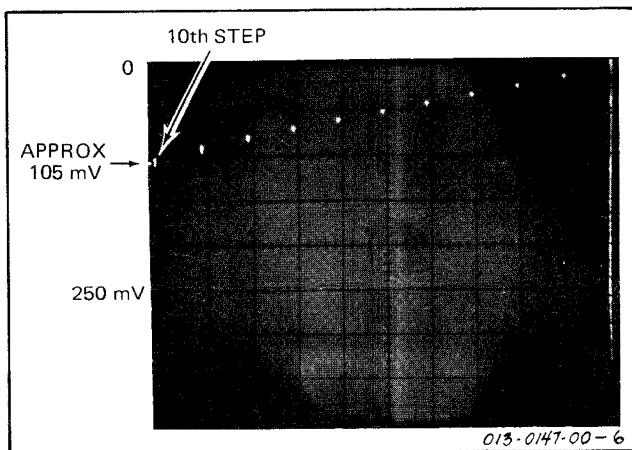

Fig. 5-1. Illustration of step 6, part f.

8. CHECK REGULATOR TEST UNIT VERTICAL ACCURACY

a. With DUT SUPPLIES switch OFF, set controls as follows:

	577
MAX PEAK VOLTS	25
MAX PEAK POWER-WATTS	100 ²
VARIABLE COLLECTOR %	100
COLLECTOR SUPPLY POLARITY	+DC (-DC for Negative Test Unit)

All Dark Gray Buttons and Knobs In Except:

STEP FAMILY	SINGLE
STEP/OFFSET POLARITY NORM	out
STEP/OFFSET AMPL	.05 V
OFFSET MULT	≈8.0
OFFSET AID	in
PULSED 300 μs	out
HORIZ VOLTS/DIV	200 V, COLLECTOR

	178
FUNCTION	LOAD REGULATION
VERTS UNITS/DIV	50 mV

REGULATOR TEST UNIT	
SUPPLY VOLTAGE Range	0-30
OUTPUT VOLTAGE	
COMPARISON Range	0-10
OUTPUT VOLTAGE	
COMPARISON Dial	0

b. Push 577 POWER switch to Off. Connect a patch cord (40 mil pin) on the Regulator Test Unit, between terminals A23 and B22. See Fig. 5-2. Plug the Regulator Test Unit into the 178 and turn 577 POWER on.

c. Press and hold DISPLAY ZERO button while adjusting the spot to top-center graticule line (bottom-center graticule line for Negative Test Unit) using the POSITION controls.

d. Connect a patch cord (banana-banana) between STEP GEN (on front panel) and OUTPUT SENSE. Connect DVM between OUTPUT SENSE and GND.

e. Switch DUT SUPPLIES to ON. Record DVM reading. Re-position spot to top graticule line (bottom graticule line for Negative Test Unit).

²ibid

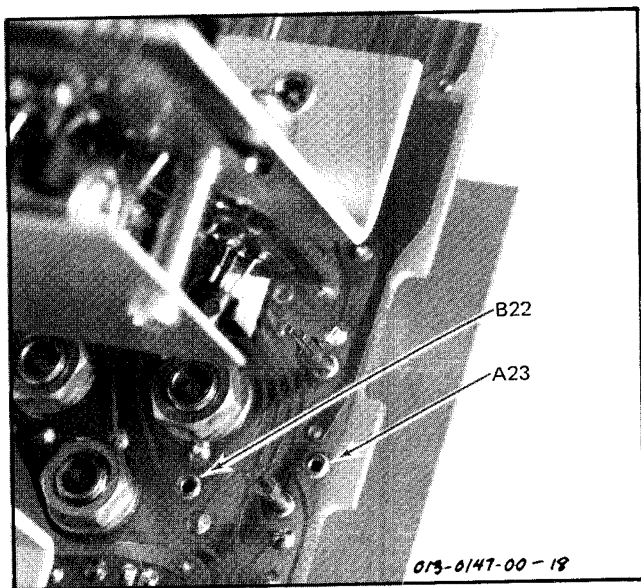

Fig. 5-2. Location of test points for terminals A23 and B22.

- f. Release OFFSET ZERO to out position. Adjust OFFSET MULT to 0.400 volt above the reading noted in part 3. Note that the display moves about 8 divisions.
- g. Connect DVM between EXT SIGNAL IN and GND.
- h. Record the DVM reading.
- i. Press OFFSET ZERO button in. Read DVM and subtract the reading from that recorded in part h.
- j. CHECK—The difference in DVM reading, 4.0 V, ± 20 mV.
- k. Remove the patch.

9. CHECK SWEEP GENERATOR WAVEFORM DISTORTION

- a. With DUT SUPPLIES switch OFF, set the controls as follows:

	577
MAX PEAK VOLTS	25
MAX PEAK POWER-WATTS	100^2
VARIABLE COLLECTOR %	100
COLLECTOR SUPPLY POLARITY	+DC (kDC for Negative Test Unit)

²ibld

All Dark Gray Buttons and Knobs In Except:

STEP FAMILY	SINGLE
STEP/OFFSET	
POLARITY NORM	out (invert)
HORIZ VOLTS/DIV	2 V, COLLECTOR

178

+SUPPLY	12 V
-SUPPLY	TRACK +SUPPLY
SWEEP FREQUENCY	100 Hz
SWEEP AMPLITUDE	0
FUNCTION	LINE REGULATION
VERT UNITS/DIV	20 mV

REGULATOR TEST UNIT

SUPPLY VOLTAGE Range	0-30 V
OUTPUT VOLTAGE	
COMPARISON Range	0-10
OUTPUT VOLTAGE	
COMPARISON Dial	0

- b. Connect a 10 k Ω , 1/4% resistor between INPUT and OUTPUT.
- c. Connect a 100 Ω , 1/4% resistor between OUTPUT and GND. Set DUT SUPPLIES switch to ON.
- d. Position the spot to upper-right corner of graticule (lower-left for negative regulators).
- e. Increase SWEEP AMPLITUDE control until the display looping (separation) equals 1 minor division.
- f. CHECK—Horizontal display ≥ 5 volts (≥ 2.5 major divisions).
- g. Remove the resistors and patch cords.

10. CHECK COMMON-TERMINAL CURRENT

- a. With DUT SUPPLIES switch OFF, set controls as follows:

	577
MAX PEAK VOLTS	25
MAX PEAK POWER-WATTS	100^2
COLLECTOR SUPPLY POLARITY	+DC) -DC for Negative Test Units)
VARIABLE COLLECTOR %	100

All Dark Gray Buttons and Knobs In Except:

STEP FAMILY	SINGLE
STEP/OFFSET	
POLARITY NORM	out (invert)
PULSED 300 μ s	out
HORIZ VOLTS/DIV	STEP GEN

178

+SUPPLY	≈ 8 V (fully clockwise for Negative Test Units)
-SUPPLY	fully clockwise (≈ 8 V⁷ for Negative Test Units)
FUNCTION	I COMMON
VERT UNITS/DIV	1 mA

REGULATOR TEST UNIT

SUPPLY VOLTAGE Range 0.30 V

b. Connect a 1 k Ω , 1/4% resistor between INPUT and COMMON. Connect dVM between COMMON and GND. Switch DUT SUPPLIES to ON.

c. Press DISPLAY ZERO and position spot to top-center graticule lines (bottom-center for Negative Test Unit).

⁷To set -SUPPLY accurately, connect DVM between -SUPPLY and GND on 178 front panel (DUT SUPPLIES switch ON).

d. CHECK—DVM should read 0 V, ± 10 mV. Connect DVM across 1 k Ω resistor.

e. Adjust +SUPPLY (-SUPPLY for Negative Test Unit) for 8 divisions of display on graticule (from zero reference).

f. CHECK—Read DVM. The difference in this reading and that of part d should be 8 V, ± 240 mV.

g. Increase +SUPPLY dial (-SUPPLY for Negative Test Unit) until -OVERLOAD lamp (+OVERLOAD for Negative Test Unit) lights.

h. Decrease +SUPPLY (-SUPPLY for Negative Test Unit) until lamp just goes out.

i. Set VERT UNITS/DIV to 5 mA and press DISPLAY ZERO button to recheck reference.

j. CHECK—Read ≥ 10 mA on crt (≥ 2 graticule divisions from reference).

k. Remove resistor and patch cords. Reset -SUPPLY to TRACK +SUPPLY position.

REPLACEABLE ELECTRICAL PARTS

PARTS ORDERING INFORMATION

Replacement parts are available from or through your local Tektronix, Inc. Field Office or representative.

Changes to Tektronix instruments are sometimes made to accommodate improved components as they become available, and to give you the benefit of the latest circuit improvements developed in our engineering department. It is therefore important, when ordering parts, to include the following information in your order: Part number, instrument type or number, serial number, and modification number if applicable.

If a part you have ordered has been replaced with a new or improved part, your local Tektronix, Inc. Field Office or representative will contact you concerning any change in part number.

Change information, if any, is located at the rear of this manual.

SPECIAL NOTES AND SYMBOLS

X000 Part first added at this serial number
00X Part removed after this serial number

ITEM NAME

In the Parts List, an Item Name is separated from the description by a colon (:). Because of space limitations, an Item Name may sometimes appear as incomplete. For further Item Name identification, the U.S. Federal Cataloging Handbook H6-1 can be utilized where possible.

ABBREVIATIONS

ACTR	ACTUATOR	PLSTC	PLASTIC
ASSY	ASSEMBLY	QTZ	QUARTZ
CAP	CAPACITOR	RECP	RECEPTACLE
CER	CERAMIC	RES	RESISTOR
CKT	CIRCUIT	RF	RADIO FREQUENCY
COMP	COMPOSITION	SEL	SELECTED
CONN	CONNECTOR	SEMICOND	SEMICONDUCTOR
ELCTLT	ELECTROLYTIC	SENS	SENSITIVE
ELEC	ELECTRICAL	VAR	VARIABLE
INCAND	INCANDESCENT	WW	WIREWOUND
LED	LIGHT EMITTING DIODE	XFMR	TRANSFORMER
NONWIR	NON WIREWOUND	XTAL	CRYSTAL

CROSS INDEX—MFR. CODE NUMBER TO MANUFACTURER

Mfr. Code	Manufacturer	Address	City, State, Zip
01121	ALLEN-BRADLEY COMPANY	1201 2ND STREET SOUTH	MILWAUKEE, WI 53204
01295	TEXAS INSTRUMENTS, INC., SEMICONDUCTOR GROUP	P O BOX 5012, 13500 N CENTRAL EXPRESSWAY	DALLAS, TX 75222
02111	SPECTROL ELECTRONICS CORPORATION	17070 EAST GALE AVENUE	CITY OF INDUSTRY, CA 91745
02735	RCA CORPORATION, SOLID STATE DIVISION	ROUTE 202	SOMERVILLE, NY 08876
03508	GENERAL ELECTRIC COMPANY, SEMI-CONDUCTOR PRODUCTS DEPARTMENT	ELECTRONICS PARK	SYRACUSE, NY 13201
04222	AVX CERAMICS, DIVISION OF AVX CORP.	P O BOX 867, 19TH AVE. SOUTH	MYRTLE BEACH, SC 29577
04713	MOTOROLA, INC., SEMICONDUCTOR PROD. DIV.	5005 E MCDOWELL RD, PO BOX 20923	PHOENIX, AZ 85036
05574	VIKING INDUSTRIES, INC.	21001 NORDHOFF STREET	CHATSWORTH, CA 91311
07263	FAIRCHILD SEMICONDUCTOR, A DIV. OF FAIRCHILD CAMERA AND INSTRUMENT CORP.	464 ELLIS STREET	MOUNTAIN VIEW, CA 94042
14099	SEMTECH CORP.	652 MITCHELL RD.	NEWBURY PARK, CA 91320
14604	ELMWOOD SENSORS, INC.	1655 ELMWOOD AVENUE	CRANSTON, RI 02907
24211	GRIGSBY-BARTON INC.	3800 INDUSTRIAL DRIVE	ROLLING MEADOWS, IL 60008
27014	NATIONAL SEMICONDUCTOR CORP.	2900 SEMICONDUCTOR DR.	SANTA CLARA, CA 95051
34371	HARRIS SEMICONDUCTOR, DIV. OF HARRIS CORPORATION	P. O. BOX 883	MELBOURNE, FL 32901
56289	SPRAGUE ELECTRIC CO.	87 MARSHALL ST.	NORTH ADAMS, MA 01247
59660	TUSONIX INC.	2155 N FORBES BLVD	TUCSON, AZ 85705
72982	ERIE TECHNOLOGICAL PRODUCTS, INC.	644 W. 12TH ST.	ERIE, PA 16512
73138	BECKMAN INSTRUMENTS, INC., HELIPOT DIV.	2500 HARBOR BLVD.	FULLERTON, CA 92634
78488	STACKPOLE CARBON CO.		ST. MARYS, PA 15857
79727	C-W INDUSTRIES	550 DAVISVILLE RD., P O BOX 96	WARMINISTER, PA 18974
80009	TEKTRONIX, INC.	P O BOX 500	BEAVERTON, OR 97077
91418	RADIO MATERIALS COMPANY, DIV. OF P.R.		
	MALLORY AND COMPANY, INC.	4242 W BRYN MAWR	CHICAGO, IL 60646
91637	DALE ELECTRONICS, INC.	P. O. BOX 609	COLUMBUS, NE 68601

Replaceable Electrical Parts—013-0147-00/013-0148-00

Ckt No.	Tektronix Part No.	Serial/Model No. Eff Dscont	Name & Description	Mfr Code	Mfr Part Number
A1	670-2860-00		CKT BOARD ASSY:REGULATOR OUT	80009	670-2860-00
A2	670-3219-00		CKT BOARD ASSY:REGULATOR SUPPLY	80009	670-3219-00
	-----		(013-0147-00 ONLY)		
A3	670-3458-00		CKT BOARD ASSY:REGULATOR SUPPLY	80009	670-3458-00
	-----		(013-0148-00 ONLY)		
A1	670-2860-00		CKT BOARD ASSY:REGULATOR OUT	80009	670-2860-00
C616	283-0000-00		CAP.,FXD,CER DI:0.001UF,+100-0%,500V	59660	831-519-Z5U-102P
C617	281-0605-00		CAP.,FXD,CER DI:200PF,10%,500V	04222	7001-1375
C618	283-0000-00		CAP.,FXD,CER DI:0.001UF,+100-0%,500V	59660	831-519-Z5U-102P
C619	283-0000-00		CAP.,FXD,CER DI:0.001UF,+100-0%,500V	59660	831-519-Z5U-102P
C620	281-0523-00		CAP.,FXD,CER DI:100PF,+/-20PF,500V	72982	301-000U2M0101M
C622	281-0628-00		CAP.,FXD,CER DI:15PF,5%,500V	59660	301-000C0G0150J
C625	283-0346-00		CAP.,FXD,CER DI:0.47UF,+80-20%,100V	72982	8131-M100F474Z
C631	283-0000-00		CAP.,FXD,CER DI:0.001UF,+100-0%,500V	59660	831-519-Z5U-102P
C636	SELECTED		(SEE D.U.T. SPEC SHEET)		
C638	283-0204-00		CAP.,FXD,CER DI:0.01UF,20%,50V	72982	8121N061Z5U0103M
C639	283-0204-00		CAP.,FXD,CER DI:0.01UF,20%,50V	72982	8121N061Z5U0103M
CR615	152-0198-02		SEMICONV DEVICE:SILICON,200V,3A	14099	SS4986
CR616	152-0198-02		SEMICONV DEVICE:SILICON,200V,3A	14099	SS4986
J630	131-0820-01		CONN,RCPT,ELEC:CKT BD,10/20 CONTACT	05574	000201-5429
K601	148-0096-00		RELAY,REED:SPDT,5V,33MA	24211	GB831C
L636	276-0596-00		CORE,TOROID,FER:0.09 ID X 0.19 OD X 0.08" H	78488	57-1657
R601	303-0751-00		RES.,FXD,CMPSN:750 OHM,5%,1W	01121	GB7515
R610	311-1674-00		RES.,VAR,WW:PNL,10K OHM,0.2W	02111	534-9814
R612	321-0986-07		RES.,FXD,FILM:25K OHM,0.1%,0.125W	91637	MFF1816C25001B
R613	321-0929-07		RES.,FXD,FILM:2.5K OHM,0.10%,0.125W	91637	MFF1816C25000B
R615	311-1560-00		RES.,VAR,NONWIR:5K OHM,20%,0.50W	73138	91-82-0
R616	315-0103-00		RES.,FXD,CMPSN:10K OHM,5%,0.25W	01121	CB1035
R621	315-0201-00		RES.,FXD,CMPSN:200 OHM,5%,0.25W	01121	CB2015
R625	315-0623-00		RES.,FXD,CMPSN:62K OHM,5%,0.25W	01121	CB6235
R626	315-0153-00		RES.,FXD,CMPSN:15K OHM,5%,0.25W	01121	CB1535
R627	315-0153-00		RES.,FXD,CMPSN:15K OHM,5%,0.25W	01121	CB1535
R630	321-0385-04		RES.,FXD,FILM:100K OHM,0.1%,0.125W	91637	MFF1816D10002B
R631	315-0100-00		RES.,FXD,CMPSN:10 OHM,5%,0.25W	01121	CB1005
R632	321-0385-04		RES.,FXD,FILM:100K OHM,0.1%,0.125W	91637	MFF1816D10002B
R633	321-0756-04		RES.,FXD,FILM:50K OHM,0.1%,0.125W	91637	MFF1816D50001B
R634	315-0204-00		RES.,FXD,CMPSN:200K OHM,5%,0.25W	01121	CB2045
R635	321-0756-04		RES.,FXD,FILM:50K OHM,0.1%,0.125W	91637	MFF1816D50001B
R636	315-0220-00		RES.,FXD,CMPSN:22 OHM,5%,0.25W	01121	CB2205
R637	315-0220-00		RES.,FXD,CMPSN:22 OHM,5%,0.25W	01121	CB2205
R638	315-0511-00		RES.,FXD,CMPSN:510 OHM,5%,0.25W	01121	CB5115
S610	260-0984-00		SWITCH,SLIDE:DP3T,0.5A,125V	79727	G-128-S-0012
S625	260-0723-00		SWITCH,SLIDE:DPDT,0.5A,125VAC	79727	GF126-0028
U610	156-0067-00		MICROCIRCUIT,LI:OPERATIONAL AMPLIFIER	02735	85145
U615	156-0105-00		MICROCIRCUIT,LI:OPERATIONAL AMPLIFIER	27014	LM301AN
U620	156-0317-00		MICROCIRCUIT,LI:OPERATIONAL AMPLIFIER	34371	HA2-2625-5
U630	156-0200-00		MICROCIRCUIT,LI:OPERATIONAL AMPLIFIER	04713	MC1456P1
VR638	152-0291-00		SEMICONV DEVICE:ZENER,1W,20V,5%	04713	1N3027B
VR639	152-0291-00		SEMICONV DEVICE:ZENER,1W,20V,5%	04713	1N3027B

Replaceable Electrical Parts—013-0147-00/013-0148-00

Ckt No.	Tektronix Part No.	Serial/Model No. Eff Dscont	Name & Description	Mfr Code	Mfr Part Number
A2	670-3219-00 -----		CKT BOARD ASSY:REGULATOR SUPPLY (A2, 013-0147-00 ONLY)	80009	670-3219-00
C665	290-0270-00		CAP., FXD, ELCTLT:8.2UF, 20%, 60V	56289	150D825X0060R2
C670	290-0177-00		CAP., FXD, ELCTLT:1UF, 20%, 50V	56289	162D105X0050CD2
C673	290-0332-00		CAP., FXD, ELCTLT:43UF, 10%, 100V	56289	109D436X9100T2
C674	283-0023-00		CAP., FXD, CER DI:0.1UF, +80-20%, 12V	91418	MX0104Z1205R5
CR642	152-0198-02		SEMICONV DEVICE:SILICON, 200V, 3A	14099	SS4986
CR644	152-0198-00		SEMICONV DEVICE:SILICON, 200V, 3A	03508	1N5624
CR645	152-0061-00		SEMICONV DEVICE:SILICON, 175V, 100MA	07263	FDH2161
CR648	152-0061-00		SEMICONV DEVICE:SILICON, 175V, 100MA	07263	FDH2161
CR655	152-0141-02		SEMICONV DEVICE:SILICON, 30V, 150MA	01295	1N4152R
CR673	152-0198-02		SEMICONV DEVICE:SILICON, 200V, 3A	14099	SS4986
Q640	151-0391-00		TRANSISTOR:SILICON, PNP	80009	151-0391-00
Q642	153-0628-00		TRANSISTOR:SELECTED	80009	153-0628-00
Q644	151-0485-00		TRANSISTOR:SILICON, NPN	80009	151-0485-00
Q645	151-0134-00		TRANSISTOR:SILICON, PNP	80009	151-0134-00
Q648	151-0350-00		TRANSISTOR:SILICON, PNP	04713	SPS6700
Q650	151-0347-00		TRANSISTOR:SILICON, NPN	56289	2N5551
Q655	151-0302-00		TRANSISTOR:SILICON, NPN	07263	S038487
Q660	151-0347-00		TRANSISTOR:SILICON, NPN	56289	2N5551
Q664	153-0628-00		TRANSISTOR:SELECTED	80009	153-0628-00
Q670	151-0342-00		TRANSISTOR:SILICON, PNP	07263	S035928
Q672	151-0522-00		TRANSISTOR:SILICON, TRIAC, 400V	03508	SC141DX164
Q676	153-0630-00		TRANSISTOR:MATCHED PAIR	80009	153-0630-00
Q678	151-0419-00		TRANSISTOR:SILICON, PNP	04713	SJ6930
R642	315-0102-00		RES., FXD, CMPSN:1K OHM, 5%, 0.25W	01121	CB1025
R644	315-0101-00		RES., FXD, CMPSN:100 OHM, 5%, 0.25W	01121	CB1015
R645	304-0102-00		RES., FXD, CMPSN:1K OHM, 10%, 1W	01121	GB1021
R646	315-0104-00		RES., FXD, CMPSN:100K OHM, 5%, 0.25W	01121	CB1045
R647	315-0332-00		RES., FXD, CMPSN:3.3K OHM, 5%, 0.25W	01121	CB3325
R648	315-0511-00		RES., FXD, CMPSN:510 OHM, 5%, 0.25W	01121	CB5115
R650	307-0109-00		RES., FXD, CMPSN:8.2 OHM, 5%, 0.25W	01121	CB82G5
R652	315-0202-00		RES., FXD, CMPSN:2K OHM, 5%, 0.25W	01121	CB2025
R654	315-0202-00		RES., FXD, CMPSN:2K OHM, 5%, 0.25W	01121	CB2025
R655	321-0286-00		RES., FXD, FILM:9.31K OHM, 1%, 0.125W	91637	MFF1816G93100F
R660	307-0109-00		RES., FXD, CMPSN:8.2 OHM, 5%, 0.25W	01121	CB82G5
R661	308-0436-00		RES., FXD, WW:2K OHM, 0.1%, 3W	91637	RS2B-110-20000B
R662	308-0436-00		RES., FXD, WW:2K OHM, 0.1%, 3W	91637	RS2B-110-20000B
R664	315-0103-00		RES., FXD, CMPSN:10K OHM, 5%, 0.25W	01121	CB1035
R665	303-0122-00		RES., FXD, CMPSN:1.2K OHM, 5%, 1W	01121	GB1225
R671	301-0822-00		RES., FXD, CMPSN:8.2K OHM, 5%, 0.50W	01121	EB8225
R672	315-0104-00		RES., FXD, CMPSN:100K OHM, 5%, 0.25W	01121	CB1045
R674	315-0103-00		RES., FXD, CMPSN:10K OHM, 5%, 0.25W	01121	CB1035
R675	315-0102-00		RES., FXD, CMPSN:1K OHM, 5%, 0.25W	01121	CB1025
R676	315-0121-00		RES., FXD, CMPSN:120 OHM, 5%, 0.25W	01121	CB1215
R671	301-0822-00		RES., FXD, CMPSN:8.2K OHM, 5%, 0.50W	01121	EB8225
R672	315-0104-00		RES., FXD, CMPSN:100K OHM, 5%, 0.25W	01121	CB1045
R674	315-0103-00		RES., FXD, CMPSN:10K OHM, 5%, 0.25W	01121	CB1035
R675	315-0102-00		RES., FXD, CMPSN:1K OHM, 5%, 0.25W	01121	CB1025
R676	315-0121-00		RES., FXD, CMPSN:120 OHM, 5%, 0.25W	01121	CB1215
R677	308-0242-00		RES., FXD, WW:0.25 OHM, 5%, 5W	91637	RS2A-ER2500K
R678	315-0100-00		RES., FXD, CMPSN:10 OHM, 5%, 0.25W	01121	CB1005
S670	260-1663-00		SWITCH, THRMSTC:C, OPEN 100, CL88, 8A, 250V	14604	TYPE2450
VR647	152-0461-00		SEMICONV DEVICE:ZENER, 0.4W, 6.2V, 5%	04713	1N821
VR671	152-0229-00		SEMICONV DEVICE:ZENER, 1W, 39V, 5%	04713	1N3034B
VR672	152-0168-00		SEMICONV DEVICE:ZENER, 0.4W, 12V, 5%	04713	SZG35009K4
VR674	152-0513-00		SEMICONV DEVICE:ZENER, 1W, 91V, 5%	80009	152-0513-00

Replaceable Electrical Parts—013-0147-00/013-0148-00

Ckt No.	Tektronix Part No.	Serial/Model No. Eff Dscont	Name & Description	Mfr Code	Mfr Part Number
A3	670-3458-00 -----		CKT BOARD ASSY:REGULATOR SUPPLY (A3, 013-0148-00 ONLY)	80009	670-3458-00
C770	290-0177-00		CAP., FXD, ELCTLT: 1UF, 20%, 50V	56289	162D105X0050CD2
C765	290-0270-00		CAP., FXD, ELCTLT: 8.2UF, 20%, 60V	56289	150D825X0060R2
C773	290-0332-00		CAP., FXD, ELCTLT: 43UF, 10%, 100V	56289	109D436X9100T2
C774	283-0023-00		CAP., FXD, CER DI: 0.1UF, +80-20%, 12V	91418	MX0104Z1205R5
CR742	152-0198-02		SEMICONV DEVICE: SILICON, 200V, 3A	14099	SS4986
CR744	152-0198-02		SEMICONV DEVICE: SILICON, 200V, 3A	14099	SS4986
CR745	152-0061-00		SEMICONV DEVICE: SILICON, 175V, 100MA	07263	FDH2161
CR748	152-0061-00		SEMICONV DEVICE: SILICON, 175V, 100MA	07263	FDH2161
CR755	152-0141-02		SEMICONV DEVICE: SILICON, 30V, 150MA	01295	1N4152R
CR773	152-0198-02		SEMICONV DEVICE: SILICON, 200V, 3A	14099	SS4986
Q740	151-0390-00		TRANSISTOR: SILICON, NPN	04713	SPS3414
Q742	153-0630-00		TRANSISTOR: MATCHED PAIR	80009	153-0630-00
Q744	151-0419-00		TRANSISTOR: SILICON, PNP	04713	SJ6930
Q745	151-0121-00		TRANSISTOR: SILICON, NPN	04713	SM7769
Q748	151-0347-00		TRANSISTOR: SILICON, NPN	56289	2N5551
Q750	151-0350-00		TRANSISTOR: SILICON, PNP	04713	SPS6700
Q755	151-0301-00		TRANSISTOR: SILICON, PNP	27014	2N2907A
Q760	151-0350-00		TRANSISTOR: SILICON, PNP	04713	SPS6700
Q764	153-0630-00		TRANSISTOR: MATCHED PAIR	80009	153-0630-00
Q770	151-0190-00		TRANSISTOR: SILICON, NPN	07263	S032677
Q772	151-0522-00		TRANSISTOR: SILICON, TRIAC, 400V	03508	SC141DX164
Q776	153-0628-00		TRANSISTOR: SELECTED	80009	153-0628-00
Q778	151-0485-00		TRANSISTOR: SILICON, NPN	80009	151-0485-00
R742	315-0102-00		RES., FXD, CMPSN: 1K OHM, 5%, 0.25W	01121	CB1025
R744	315-0101-00		RES., FXD, CMPSN: 100 OHM, 5%, 0.25W	01121	CB1015
R745	304-0102-00		RES., FXD, CMPSN: 1K OHM, 10%, 1W	01121	GB1021
R746	315-0104-00		RES., FXD, CMPSN: 100K OHM, 5%, 0.25W	01121	CB1045
R747	315-0332-00		RES., FXD, CMPSN: 3.3K OHM, 5%, 0.25W	01121	CB3325
R748	315-0511-00		RES., FXD, CMPSN: 510 OHM, 5%, 0.25W	01121	CB5115
R750	307-0109-00		RES., FXD, CMPSN: 8.2 OHM, 5%, 0.25W	01121	CB82G5
R752	315-0202-00		RES., FXD, CMPSN: 2K OHM, 5%, 0.25W	01121	CB2025
R754	315-0202-00		RES., FXD, CMPSN: 2K OHM, 5%, 0.25W	01121	CB2025
R755	321-0286-00		RES., FXD, FILM: 9.31K OHM, 1%, 0.125W	91637	MFF1816G93100F
R760	307-0109-00		RES., FXD, CMPSN: 8.2 OHM, 5%, 0.25W	01121	CB82G5
R761	308-0436-00		RES., FXD, WW: 2K OHM, 0.1%, 3W	91637	RS2B-110-20000B
R762	308-0436-00		RES., FXD, WW: 2K OHM, 0.1%, 3W	91637	RS2B-110-20000B
R764	315-0103-00		RES., FXD, CMPSN: 10K OHM, 5%, 0.25W	01121	CB1035
R765	303-0122-00		RES., FXD, CMPSN: 1.2K OHM, 5%, 1W	01121	GB1225
R771	301-0822-00		RES., FXD, CMPSN: 8.2K OHM, 5%, 0.50W	01121	EB8225
R772	315-0101-00		RES., FXD, CMPSN: 100 OHM, 5%, 0.25W	01121	CB1015
R774	315-0103-00		RES., FXD, CMPSN: 10K OHM, 5%, 0.25W	01121	CB1035
R775	315-0102-00		RES., FXD, CMPSN: 1K OHM, 5%, 0.25W	01121	CB1025
R776	315-0121-00		RES., FXD, CMPSN: 120 OHM, 5%, 0.25W	01121	CB1215
R777	308-0242-00		RES., FXD, WW: 0.25 OHM, 5%, 5W	91637	RS2A-ER2500K
R778	315-0100-00		RES., FXD, CMPSN: 10 OHM, 5%, 0.25W	01121	CB1005
S770	260-1663-00		SWITCH, THRMSTC: C, OPEN 100, CL88, 8A, 250V	14604	TYPE2450
VR747	152-0461-00		SEMICONV DEVICE: ZENER, 0.4W, 6.2V, 5%	04713	1N821
VR771	152-0229-00		SEMICONV DEVICE: ZENER, 1W, 39V, 5%	04713	1N3034B
VR772	152-0168-00		SEMICONV DEVICE: ZENER, 0.4W, 12V, 5%	04713	SZG35009K4
VR774	152-0513-00		SEMICONV DEVICE: ZENER, 1W, 91V, 5%	80009	152-0513-00

DIAGRAMS AND CIRCUIT BOARD ILLUSTRATIONS

Symbols and Reference Designators

Electrical components shown on the diagrams are in the following units unless noted otherwise:

- Capacitors = Values one or greater are in picofarads (pF).
Values less than one are in microfarads (μF).
- Resistors = Ohms (Ω).

Graphic symbols and class designation letters are based on ANSI Standard Y32.2-1975.

Logic symbology is based on ANSI Y32.14-1973 in terms of positive logic. Logic symbols depict the logic function performed and may differ from the manufacturer's data.

The overline on a signal name indicates that the signal performs its intended function when it goes to the low state.

Abbreviations are based on ANSI Y1.1-1972.

Other ANSI standards that are used in the preparation of diagrams by Tektronix, Inc. are:

- Y14.15, 1966 Drafting Practices.
- Y14.2, 1973 Line Conventions and Lettering.
- Y10.5, 1968 Letter Symbols for Quantities Used in Electrical Science and Electrical Engineering.

The following prefix letters are used as reference designators to identify components or assemblies on the diagrams.

A	Assembly, separable or repairable (circuit board, etc)	H	Heat dissipating device (heat sink, heat radiator, etc)	S	Switch or contactor
AT	Attenuator, fixed or variable	HR	Heater	T	Transformer
B	Motor	HY	Hybrid circuit	TC	Thermocouple
BT	Battery	J	Connector, stationary portion	TP	Test point
C	Capacitor, fixed or variable	K	Relay	U	Assembly, inseparable or non-repairable (integrated circuit, etc.)
CB	Circuit breaker	L	Inductor, fixed or variable	V	Electron tube
CR	Diode, signal or rectifier	M	Meter	VR	Voltage regulator (zener diode, etc.)
DL	Delay line	P	Connector, movable portion	W	Wirestrap or cable
DS	Indicating device (lamp)	Q	Transistor or silicon-controlled rectifier	Y	Crystal
E	Spark Gap, Ferrite bead	R	Resistor, fixed or variable	Z	Phase shifter
F	Fuse	RT	Thermistor		
FL	Filter				

The following special symbols may appear on the diagrams:

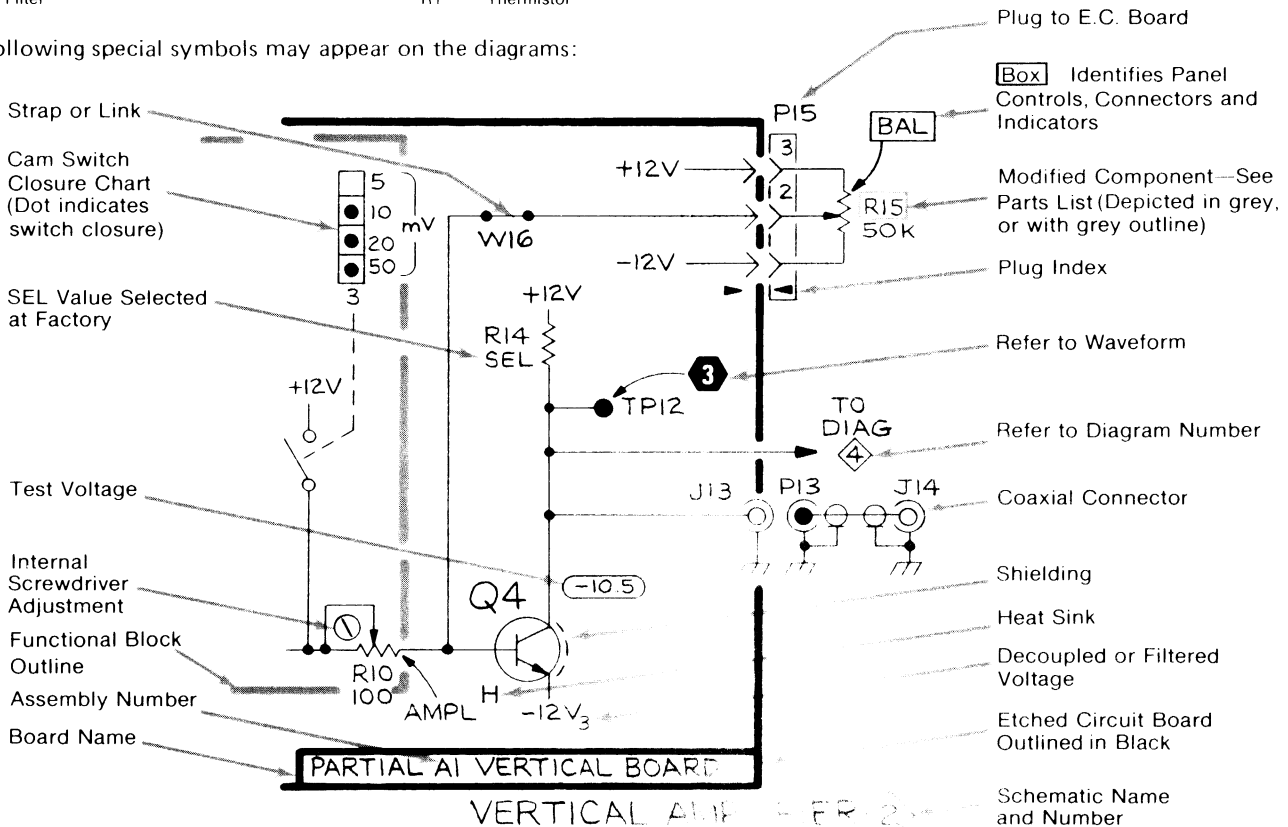

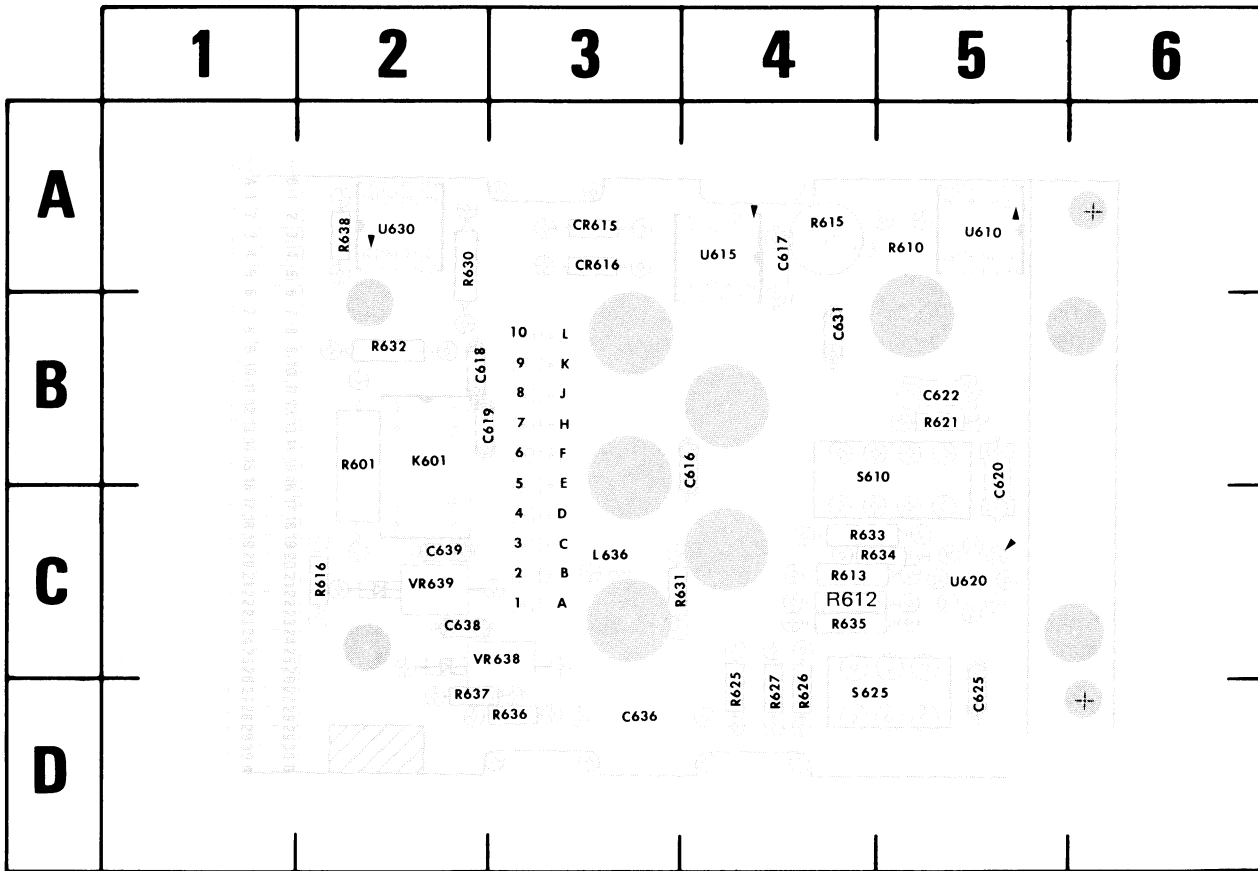

Fig. 7-1. A1—Main Circuit Board.

CKT NO	GRID LOC	CKT NO	GRID LOC
C616	3B	R621	5B
C617	4A	R625	4D
C618	2B	R626	4D
C619	2B	R627	4D
C620	5B	R630	2A
C622	5B	R631	3C
C625	5D	R632	2B
C631	4B	R633	4C
C636	3D	R634	4C
C638	2C	R635	4C
C639	2C	R636	3D
		R637	2D
		R638	2A
CR615	3A		
CR616	3A	S610	4B
		S625	4D
K601	2B		
		U610	5A
L636	3C	U615	4A
		U620	5C
R601	2B	U630	2A
R610	5A		
R612	4C	VR638	2C
R613	4C	VR639	2C
R615	4A		
R616	2C		

(A)

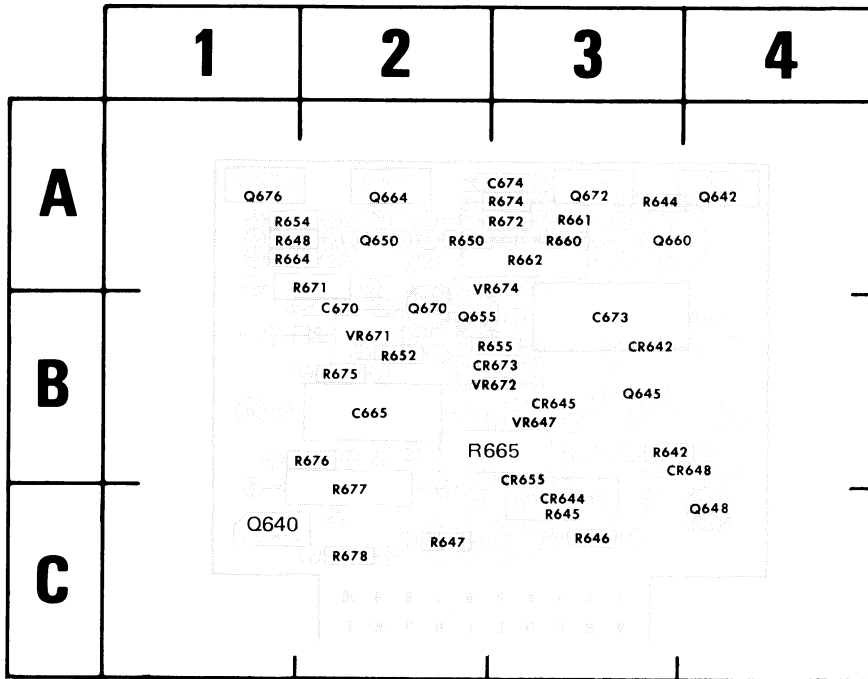

Fig. 7-2. A2—Positive Supply card.

CKT NO	GRID LOC	CKT NO	GRID LOC
C665	2B	R645	3C
C670	2B	R646	3C
C673	3B	R647	2C
C674	3A	R648	1A
		R650	2A
CR642	3B	R652	2B
CR644	3C	R654	1A
CR645	3B	R655	2B
CR648	4B	R660	3A
CR655	3B	R661	3A
CR673	3B	R662	3A
		R664	1A
Q640	1C	R665	2B
Q642	4A	R671	2A
Q645	3B	R672	3A
Q648	4C	R674	3A
Q650	2A	R675	2B
Q655	2B	R676	2B
Q660	3A	R677	2C
Q664	2A	R678	2C
Q670	2B		
Q672	3A	VR647	3B
Q676	1A	VR671	2B
R642	3B	VR672	3B
R644	3A	VR674	3A

(A)

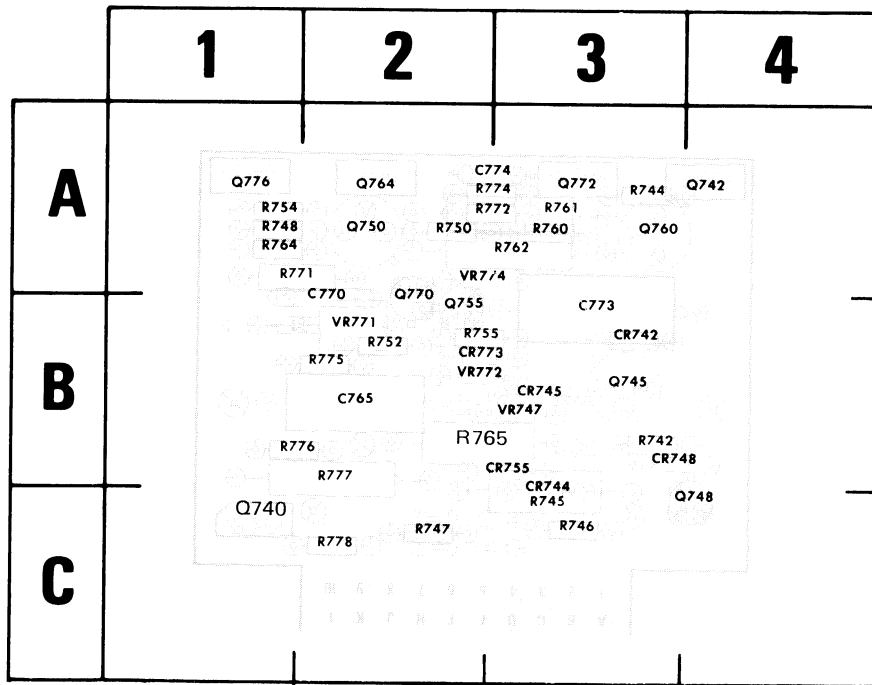
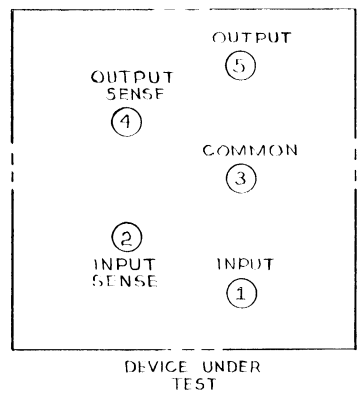
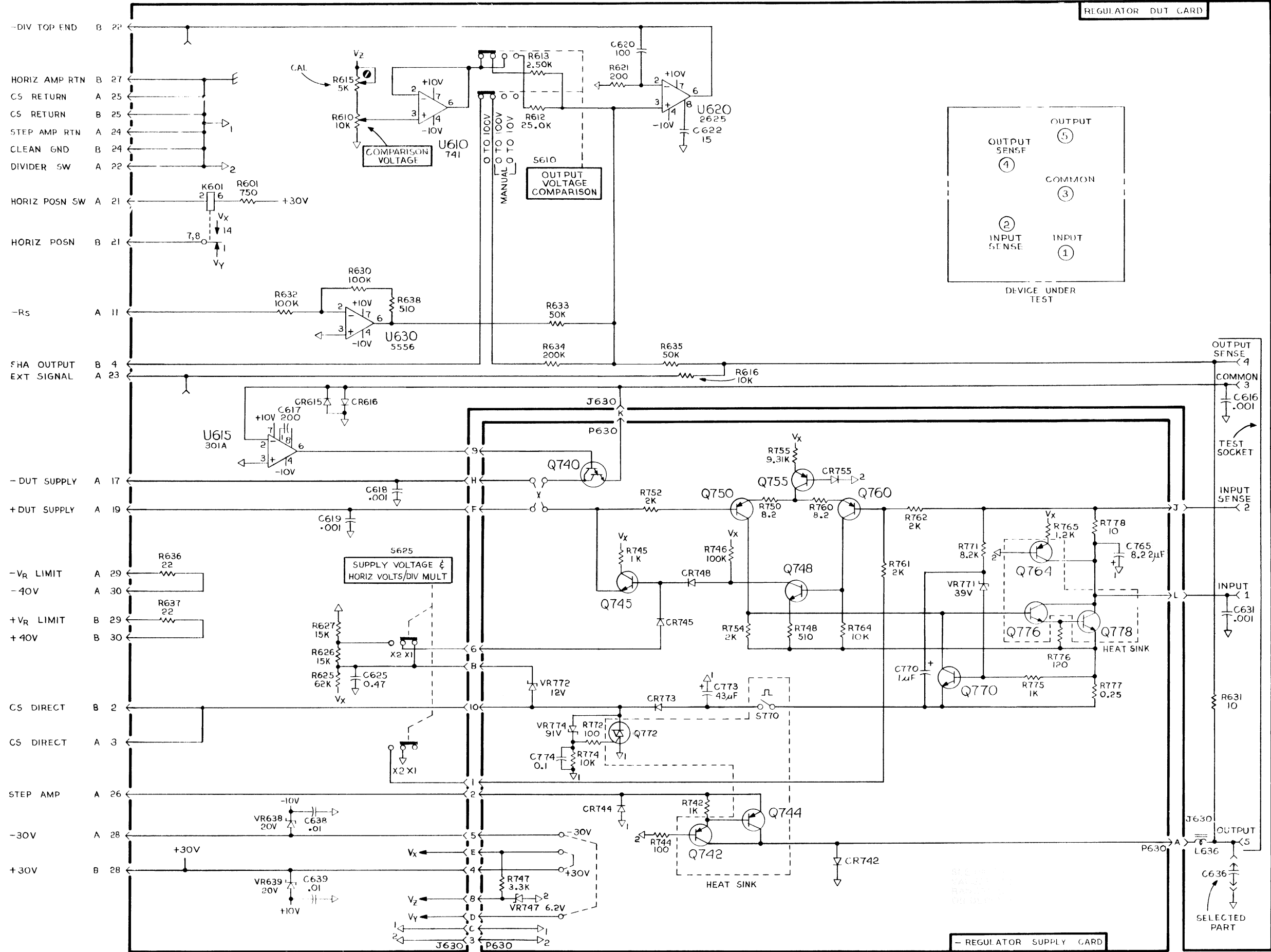

Fig. 7-4. A3—Negative Supply card.

CKT NO	GRID LOC	CKT NO	GRID LOC
C765	2B	R745	3C
C770	2B	R746	3C
C773	3B	R747	2C
C774	3A	R748	1A
		R750	2A
CR742	3B	R752	2B
CR744	3C	R754	1A
CR745	3B	R755	2B
CR748	4B	R760	3A
CR755	3B	R761	3A
CR773	3B	R762	3A
		R764	1A
Q740	1C	R765	2B
Q742	4A	R771	2A
Q745	3B	R772	3A
Q748	4C	R774	3A
Q750	2A	R775	2B
Q755	2B	R776	2B
Q760	3A	R777	2C
Q764	2A	R778	2C
Q770	2B		
Q772	3A	VR747	3B
Q776	1A	VR771	2B
R742	3B	VR772	3B
R744	3A	VR774	3A

Ⓐ



NEG. REGULATOR TEST UNIT



REPLACEABLE MECHANICAL PARTS

PARTS ORDERING INFORMATION

Replacement parts are available from or through your local Tektronix, Inc. Field Office or representative.

Changes to Tektronix instruments are sometimes made to accommodate improved components as they become available, and to give you the benefit of the latest circuit improvements developed in our engineering department. It is therefore important, when ordering parts, to include the following information in your order: Part number, instrument type or number, serial number, and modification number if applicable.

If a part you have ordered has been replaced with a new or improved part, your local Tektronix, Inc. Field Office or representative will contact you concerning any change in part number.

Change information, if any, is located at the rear of this manual.

SPECIAL NOTES AND SYMBOLS

X000 Part first added at this serial number
00X Part removed after this serial number

FIGURE AND INDEX NUMBERS

Items in this section are referenced by figure and index numbers to the illustrations.

INDENTATION SYSTEM

This mechanical parts list is indented to indicate item relationships. Following is an example of the indentation system used in the description column.

```

1 2 3 4 5           Name & Description
Assembly and/or Component
Attaching parts for Assembly and/or Component
    - - - * - - -
Detail Part of Assembly and/or Component
Attaching parts for Detail Part
    - - - * - - -
Parts of Detail Part
Attaching parts for Parts of Detail Part
    - - - * - - -
  
```

Attaching Parts always appear in the same indentation as the item it mounts, while the detail parts are indented to the right. Indented items are part of, and included with, the next higher indentation. The separation symbol - - - * - - - indicates the end of attaching parts.

Attaching parts must be purchased separately, unless otherwise specified.

ITEM NAME

In the Parts List, an Item Name is separated from the description by a colon (:). Because of space limitations, an Item Name may sometimes appear as incomplete. For further Item Name identification, the U.S. Federal Cataloging Handbook H6-1 can be utilized where possible.

ABBREVIATIONS

"	INCH	ELCTRN	ELECTRON	IN	INCH	SE	SINGLE END
#	NUMBER SIZE	ELEC	ELECTRICAL	INCAND	INCANDESCENT	SECT	SECTION
ACTR	ACTUATOR	ELCTLT	ELECTROLYTIC	INSUL	INSULATOR	SEMICOND	SEMICONDUCTOR
ADPTR	ADAPTER	ELEM	ELEMENT	INTL	INTERNAL	SHLD	SHIELD
ALIGN	ALIGNMENT	EPL	ELECTRICAL PARTS LIST	LPHLDR	LAMPHOLDER	SHLDR	SHOULDERED
AL	ALUMINUM	EQPT	EQUIPMENT	MACH	MACHINE	SKT	SOCKET
ASSEM	ASSEMBLED	EXT	EXTERNAL	MECH	MECHANICAL	SL	SLIDE
ASSY	ASSEMBLY	FIL	FILLISTER HEAD	MTG	MOUNTING	SLFLKG	SELF-LOCKING
ATTEN	ATTENUATOR	FLEX	FLEXIBLE	NIP	NIPPLE	SLVNG	SLEEVING
AWG	AMERICAN WIRE GAGE	FLH	FLAT HEAD	NON WIRE	NOT WIRE WOUND	SPR	SPRING
BD	BOARD	FLTR	FILTER	OSD	ORDER BY DESCRIPTION	SQ	SQUARE
BRKT	BRACKET	FR	FRAME or FRONT	OD	OUTSIDE DIAMETER	SST	STAINLESS STEEL
BRS	BRASS	FSTNR	FASTENER	OVH	OVAL HEAD	STL	STEEL
BRZ	BRONZE	FT	FOOT	PH BRZ	PHOSPHOR BRONZE	SW	SWITCH
BSHG	BUSHING	FXD	FIXED	PL	PLAIN or PLATE	T	TUBE
CAB	CABINET	GSKT	GASKET	PLSTC	PLASTIC	TERM	TERMINAL
CAP	CAPACITOR	HDL	HANDLE	PN	PART NUMBER	THD	THREAD
CER	CERAMIC	HEX	HEXAGON	PNH	PAN HEAD	THK	THICK
CHAS	CHASSIS	HEX HD	HEXAGONAL HEAD	PWR	POWER	TNSN	TENSION
CKT	CIRCUIT	HEX SOC	HEXAGONAL SOCKET	RCPT	RECEPTACLE	TPG	TAPPING
COMP	COMPOSITION	HLCPS	HELICAL COMPRESSION	RES	RESISTOR	TRH	TRUSS HEAD
CONN	CONNECTOR	HLEXT	HELICAL EXTENSION	RGD	RIGID	V	VOLTAGE
COV	COVER	HV	HIGH VOLTAGE	RLF	RELIEF	VAR	VARIABLE
CPLG	COUPLING	IC	INTEGRATED CIRCUIT	RTNR	RETAINER	W/	WITH
CRT	CATHODE RAY TUBE	ID	INSIDE DIAMETER	SCH	SOCKET HEAD	WSHR	WASHER
DEG	DEGREE	IDENT	IDENTIFICATION	SCOPE	OSCILLOSCOPE	XFMR	TRANSFORMER
DWR	DRAWER	IMPLR	IMPELLER	SCR	SCREW	XSTR	TRANSISTOR

CROSS INDEX—MFR. CODE NUMBER TO MANUFACTURER

Mfr. Code	Manufacturer	Address	City, State, Zip
00779	AMP, INC.	P O BOX 3608	HARRISBURG, PA 17105
01295	TEXAS INSTRUMENTS, INC., SEMICONDUCTOR GROUP	P O BOX 5012, 13500 N CENTRAL EXPRESSWAY	DALLAS, TX 75222
02768	ILLINOIS TOOL WORKS, INC., FASTEX DIV.	195 ALGONQUIN ROAD	DES PLAINES, IL 60016
05129	KILO ENGINEERING COMPANY	2015 D	LA VERNE, CA 91750
05574	VIKING INDUSTRIES, INC.	21001 NORDHOFF STREET	CHATSWORTH, CA 91311
14604	ELMWOOD SENSORS, INC.	1655 ELMWOOD AVENUE	CRANSTON, RI 02907
22526	BERG ELECTRONICS, INC.	YOUK EXPRESSWAY	NEW CUMBERLAND, PA 17070
23050	PRODUCT COMPONENTS CORP	30 LORRAINE AVE.	MT VERNON, NY 10553
52905	SIMPLEX MFG. COMPANY	5224 NE 42ND AVENUE	PORTLAND, OREGON 97218
71279	CAMBRIDGE THERMIONIC CORP.	445 CONCORD AVE.	CAMBRIDGE, MA 02138
73743	FISCHER SPECIAL MFG. CO.	446 MORGAN ST.	CINCINNATI, OH 45206
73803	TEXAS INSTRUMENTS, INC., METALLURGICAL MATERIALS DIV.	34 FOREST STREET	ATTLEBORO, MA 02703
74970	JOHNSON, E. F., CO.	299 10TH AVE. S. W.	WASECA, MN 56093
78189	ILLINOIS TOOL WORKS, INC. SHAKEPROOF DIVISION	ST. CHARLES ROAD	ELGIN, IL 60120
80009	TEKTRONIX, INC.	P O BOX 500	BEAVERTON, OR 97077
83330	SMITH, HERMAN H., INC.	812 SNEDIKER AVE.	BROOKLYN, NY 11207
83385	CENTRAL SCREW CO.	2530 CRESCENT DR.	BROADVIEW, IL 60153
86928	SEASTROM MFG. COMPANY, INC.	701 SONORA AVENUE	GLENDALE, CA 91201
88245	LITTON SYSTEMS, INC., USECO DIV.	13536 SATICOY ST.	VAN NUYS, CA 91409

Replaceable Mechanical Parts—013-0147-00/013-0148-00

Fig. & Index No.	Tektronix Part No.	Serial/Model No. Eff	Dscont	Qty	1	2	3	4	5	Name & Description	Mfr Code	Mfr Part Number
1-	013-0147-00			1						TEST UNIT, RGLTR: 3 TERM POS	80009	013-0147-00
	013-0148-00			1						TEST UNIT, RGLTR: NEGATIVE REGULATOR	80009	013-0148-00
-1	-----			1						. CKT BOARD ASSY: D.U.T. REGULATOR (SEE A1 REPL) (ATTACHING PARTS)		
-2	211-0116-00			2						. SCR, ASSEM WSHR: 4-40 X 0.312 INCH, PNH BRS	83385	OBD
	-----									----- * -----		
-3	331-0247-00			1						. . DIAL, CONTROL: 10 TURN	05129	771-S-1
-4	200-1636-00			1						. . COVER, CKT BOARD: OUT REGISTER (ATTACHING PARTS)	80009	200-1636-00
-5	211-0148-00			1						. . SCREW, MACHINE: 4-40 X 0.312 INCH, PNH STL	83385	OBD
-6	220-0601-00			2						. . NUT, PLAIN, CAP.: 4-40 X 0.25 INCH HEX, BRS	73743	93261-03
										----- * -----		
-7	348-0023-00			2						. . PLUG, HOLE:	02768	207090201000101
-8	200-1642-00			1						. . COVER, CKT BOARD: BOTTOM	80009	200-1642-00
-9	200-1480-00			2						. . COVER, SLIDE SW: DARK GRAY PLASTIC	80009	200-1480-00
-10	210-1118-00			2						. . WASHER, FLAT: 0.253 ID X 0.03 THK, ACETAL	86928	OBD
-11	-----			1						. . RES., VAR: (SEE R610 REPL) (ATTACHING PARTS)		
-12	129-0504-00			1						. . SPACER, POST: 0.41 L, 0.25-32, AL, 0.375 HEX	80009	129-0504-00
-13	361-0624-00			1						. . SPACER, RING: 0.082 L X 0.29 ID, AL	80009	361-0624-00
-14	210-0905-00			1						. . WASHER, FLAT: 0.256 ID X 0.05 THK, BRS	83385	OBD
										----- * -----		
-15	386-1544-01			1						. . PL, MTG, TEST ADA: 5 HOLE	80009	386-1544-01
-16	131-0031-00			5						. . JACK, TIP: 0.635 INCH LONG W/LUG (ATTACHING PARTS)	74970	108-0740-023
-17	210-0455-00			5						. . NUT, PLAIN, HEX.: 0.25-28 X 0.375 INCH, BRASS	73743	3089-402
-18	210-0905-00			5						. . WASHER, FLAT: 0.256 ID X 0.05 THK, BRS	83385	OBD
										----- * -----		
-19	361-0616-00			5						. . SPACER, SLEEVE: 0.25 L X 0.252 ID, BRS	80009	361-0616-00
-20	131-0820-01			1						. . CONN, RCPT, ELEC: CKT BD, 10/20 CONTACT	05574	000201-5429
-21	131-1497-00			2						. . CONTACT, ELEC: 0.04 DIA PIN 1 END	88245	15409
-22	136-0388-00			4						. . SOCKET, PIN TERM: U/W 0.04 DIA PIN	71279	450-3704-01-0300
-23	136-0252-04			16						. . SOCKET, PIN TERM: U/W 0.016-0.018 DIA PINS	22526	75060-007
-24	136-0514-00			3						. . SKT, PL-IN ELEC: MICRO CIRCUIT, 8 DIP	73803	CS9002-8
-25	-----			1						. CKT BD ASSY: POS REGULATOR SUPPLY (SEE S2 REPL)		
				1						. CKT BD ASSY: NEG REGULATOR SUPPLY (SEE A3 REPL)		
-26	337-2067-00			1						. . SHIELD, CKT BD: CKT BD (ATTACHING PARTS)	80009	337-2067-00
-27	211-0012-00			2						. . SCREW, MACHINE: 4-40 X 0.375, PNH STL CD PL	83385	OBD
-28	351-0184-00			2						. . POST, CKT BD MTG: 0.58 L X 0.219 OD BRS	80009	351-0184-00
										----- * -----		
-29	-----			2						. . TRANSISTOR: (SEE Q744, Q778 REPL) (ATTACHING PARTS)		
-30	211-0012-00			2						. . SCREW, MACHINE: 4-40 X 0.375, PNH STL CD PL	83385	OBD
-31	210-0406-00			2						. . NUT, PLAIN, HEX.: 4-40 X 0.188 INCH, BRS	73743	12161-50
-32	210-0004-00			2						. . WASHER, LOCK: #4 INTL, 0.015 THK, STL CD PL	78189	OBD
-33	210-0994-00			2						. . WASHER, FLAT: 0.125 ID X 0.25" OD, STL	86928	5702-201-20
-34	210-1171-00			2						. . WSHR, SHOULDERED: 0.116 ID X 0.138 INCH OD	52905	A7148516P2
-35	210-0849-00			2						. . WSHR, SHOULDERED: 0.11 ID X 0.188" OD, FIBER	83330	2151
										----- * -----		
-36	386-0786-00			2						. . INSULATOR, PLATE: XSTR, MICA	80009	386-0786-00
-37	260-1663-00			1						. . SWITCH, THRMSTC: C, OPEN 100, CL88, 8A, 250V (ATTACHING PARTS)	14604	TYPE2450
-38	211-0007-00			2						. . SCREW, MACHINE: 4-40 X 0.188 INCH, PNH STL (ATTACHING PARTS)	83385	OBD
										----- * -----		
-39	348-0031-00			2						. . GROMMET, PLASTIC: 0.156 INCH DIA	80009	348-0031-00
-40	-----			4						. . TRANSISTOR: (SE Q742, Q764, Q772, Q776 REPL) (ATTACHING PARTS)		
-41	210-0406-00			4						. . NUT, PLAIN, HEX.: 4-40 X 0.188 INCH, BRS	73743	12161-50
-42	210-0004-00			4						. . WASHER, LOCK: #4 INTL, 0.015 THK, STL CD PL	78189	OBD
-43	210-0994-00			4						. . WASHER, FLAT: 0.125 ID X 0.25" OD, STL	86928	5702-201-20
-44	210-1171-00			4						. . WSHR, SHOULDERED: 0.116 ID X 0.138 INCH OD	52905	A7148516P2
										----- * -----		

Replaceable Mechanical Parts—013-0147-00/013-0148-00

Fig. & Index No.	Tektronix Part No.	Serial/Model No.		Qty	1	2	3	4	5	Name & Description	Mfr Code	Mfr Part Number
		Eff	Dscont									
1-45	342-0202-00			4	INSULATOR, PLATE: TRANSISTOR	01295	10-21-023-106
-46	214-1860-00			1	HEAT SINK, XSTR: (2) TO-3, AL	80009	214-1860-00
-47	129-0317-00			2	POST, ELEC-MECH: 4-40 X 0.187 X 0.125 INCH L	80009	129-0317-00
-48	136-0252-04			18	SOCKET, PIN TERM: U/W 0.016-0.018 DIA PINS	22526	75060-007
-49	136-0254-01			4	SOCKET, PIN TERM: U/W 0.031 TO 0.04 DIA PINS	00779	1-331892-8
-50	333-1824-00			1						PANEL, FRONT:	80009	333-1824-00
	-----			-						(013-0147-00 ONLY)		
	333-1831-00			1						PANEL, FRONT:	80009	333-1831-00
	-----			-						(013-0148-00 ONLY)		
STANDARD ACCESSORIES												
	070-1678-00			1						MANUAL, TECH: INSTRUCTION	80009	070-1678-00

+

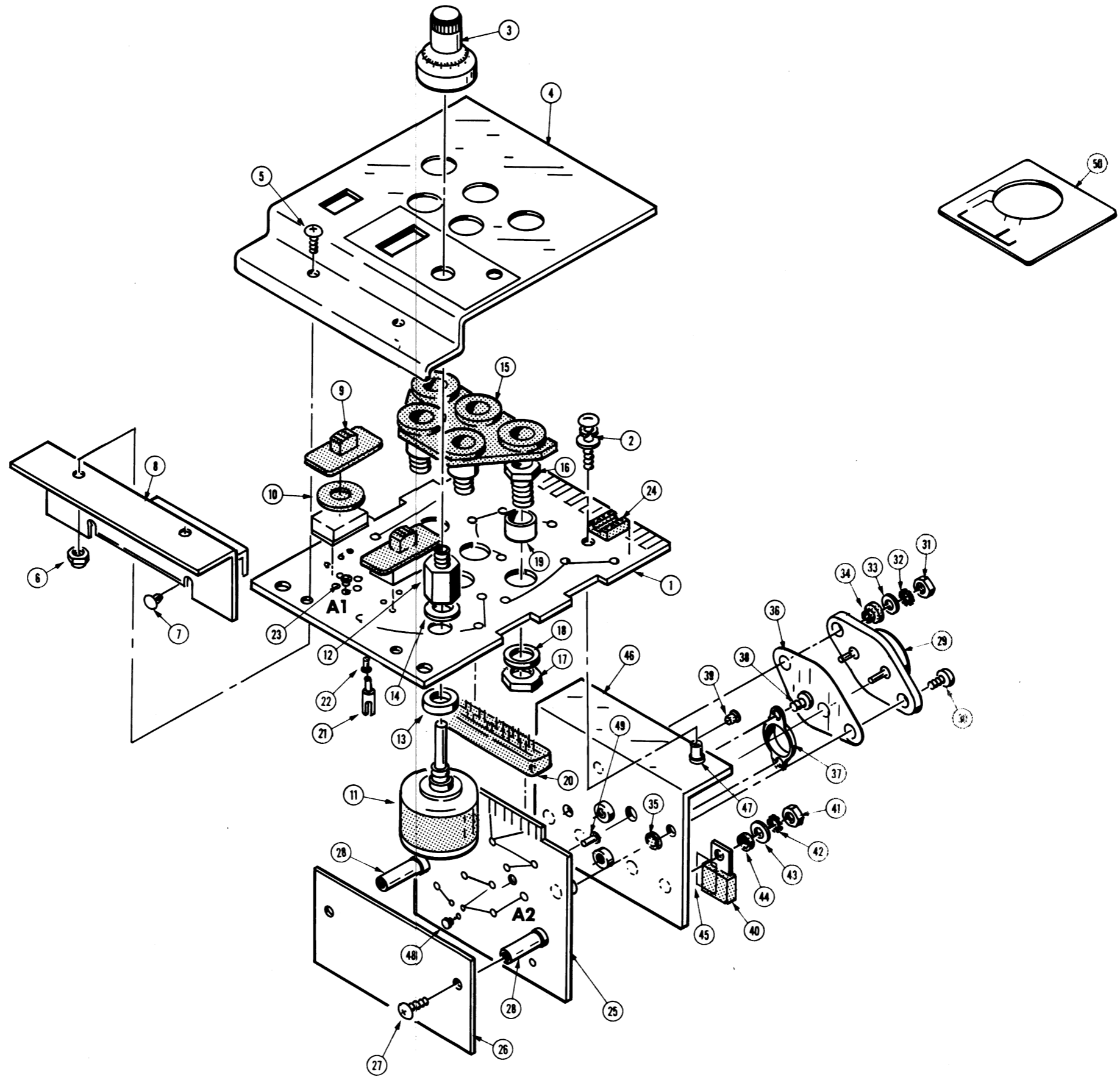

#10